

2 0 2 4
COLLECTION

USATE LE BUONE MANIGLIE



Progettare
e costruire in Italia
le maniglie
più belle al mondo.

Designing and
manufacturing in Italy
the most beautiful
handles in the world.

A Family Company.

sempre vicini a te

Proprio come una famiglia accudisce i suoi membri con amore e dedizione, così Colombo Design cura i suoi prodotti, con gli stessi valori e le medesime tradizioni, per fare di ogni ambiente una casa, senza scendere mai a compromessi sull'autenticità. Un manifesto contemporaneo dell'essere creativi, curiosi e sperimentali.

handles with care

Just like a family that handles its members with love and care, Colombo Design cares about its family of products and its production with the same values and traditions to make of any place a home, never accepting any compromise to quality and function, individuality and authenticity. Bonding heritage with creativity, curiosity and innovation.

Mission.

la qualità sensibile

Intraprendere un'impresa nel terzo millennio.

Infondere entusiasmo ai collaboratori, convinti che il fattore umano sia condizione essenziale al progresso aziendale.

Produrre secondo criteri di eccellenza nelle varie fasi di lavorazione per offrire prodotti garantiti.

Rinnovare costantemente impianti e procedure per precedere i rischi dell'obsolescenza. Questi i requisiti di Colombo Design, leader mondiale nella produzione di maniglie, presente in 93 paesi nel mondo attraverso una fitta rete di agenti e distributori. Una realtà solida, nata nel 1991, che si estende su una superficie di 100.000 mq, di cui 25.000 mq coperti, a Terno d'Isola in provincia di Bergamo.

discerning quality

Creating a business in the third millenium.

Motivating staff by recognising that human resources are essential to the company development.

Achieving manufacturing excellence at every stage of production so that products may be guaranteed.

Continuously updating machinery and manufacturing procedures in order to maintain quality levels in harmony with our environment. These are core principles of Colombo Design, world leader in the production of door handles, present in 93 countries worldwide through an extensive network of agents and distributors. A solid reality, founded in 1991, based in Terno d'Isola, in the province of Bergamo, with an area of 100,000 square meters, of which 25,000 sqm are covered.

Network.

factory

BERGAMO - ITALY

distributors

ARGENTINA
ARMENIA
AUSTRALIA
AUSTRIA
AZERBAIJAN
BAHRAIN
BELARUS
BELGIUM
BENIN
BOSNIA and HERZEGOVINA
BRAZIL
BULGARIA
CANADA
CHILE
CHINA
COLOMBIA
CROATIA
CYPRUS
CZECH REPUBLIC

DENMARK
ECUADOR
EGYPT
ESTONIA
FINLAND
FRANCE
GEORGIA
GERMANY
GREECE
HONG KONG
HUNGARY
ICELAND
INDIA
INDONESIA
IRAN
IRAQ
IRELAND
ISRAEL
IVORY COAST

JAPAN
JORDAN
KAZAKHSTAN
KENYA
KYRGYZSTAN
KUWAIT
LATVIA
LEBANON
LIBYA
LITHUANIA
MACEDONIA
MALAYSIA
MALTA
MEXICO
MOLDOVA
MONACO
MONTENEGRO
MOROCCO
NETHERLANDS

NEW CALEDONIA
NEW ZEALAND
NIGERIA
OMAN
PAKISTAN
PANAMA
PHILIPPINES
POLAND
PORTUGAL
PUERTO RICO
QATAR
ROMANIA
RUSSIA
SAUDI ARABIA
SENEGAL
SERBIA
SINGAPORE
SLOVAKIA
SLOVENIA

SOUTH AFRICA
SOUTH KOREA
SPAIN
SWEDEN
SWITZERLAND
SYRIA
THAILAND
TUNISIA
TURKEY
UAE
UKRAINE
UNITED KINGDOM
USA
UZBEKISTAN
VENEZUELA
VIETNAM
ZIMBABWE

Environmental approach.



Lo sviluppo è sostenibile se soddisfa i bisogni delle generazioni presenti senza compromettere le possibilità per le generazioni future di soddisfare i propri bisogni.

(Brundtland Report, United Nations, 1987)

è tempo di green made

Green Made significa pensare, progettare e produrre in armonia con l'ambiente.

Green Made: perché In una economia globale assume un ruolo sempre più importante la protezione delle risorse disponibili ed in particolare lo studio degli aspetti ambientali legati alle diverse attività produttive. L'aumento dei consumi delle risorse non rinnovabili (i minerali ed i metalli come pure i combustibili fossili), dovuto alla costante crescita della popolazione mondiale, impone standards di produzione che privilegino la conservazione delle risorse disponibili. I nostri processi produttivi sono frutto di una globale attenzione alla tutela dell'ambiente.

La gestione accurata di questi processi ha portato, tra le altre cose, all'ottenimento della certificazione UNI EN ISO 14001 «Sistema di gestione ambientale certificato».

Green Made: il valore Ogni singola fase di progettazione e produzione è attentamente analizzata sotto il profilo dell'impatto ambientale ed ogni scelta successiva dettata dal raggiungimento degli obiettivi di eco compatibilità. Così durante la produzione vera e propria, saranno le più avanzate tecnologie appositamente sviluppate ed i più severi controlli, effettuati da personale qualificato, a garantire Green Made by Colombo Design: un prodotto nato con il pensiero costantemente rivolto all'ambiente.

Sustainable development is development that meets the needs of the present without compromising the ability of future generations to meet their own needs.

(Brundtland Report, United Nations, 1987)

it's green made time

«Green made» means thinking, developing and manufacturing in harmony with our environment.

Green Made: why Protecting our resources is more and more important in a global economy, and in particular paying attention to reflections of manufacturing onto the environment. Increase of consumptions of non-renewable resources (minerals, metals and fossil combustibles) due to increase of population, imposes manufacturing standards which privilege conservation of the available resources and raw materials. Our production processes are the result of a total attention to environmental protection. By the accurate management of these processes we obtained the UNI EN ISO 14001 certification «Certified environmental management system».

Green Made: values Each design and production step is carefully checked with regards to the environmental impact and each following decision is taken if our eco-compatibility objectives are fully reached. This means that when we manufacture our products, the Green Made concept by Colombo Design will be guaranteed by the advanced technologies and very strict controls carried out by a very highly qualified personnel, generating a product conceived constantly thinking of the environment.

Certifications.



UNI EN ISO 9001

Sistema di gestione certificato da ICIM

Questa certificazione è valida per il seguente campo applicativo:
Progettazione e fabbricazione di maniglie, complementi per arredamento e di accessori per l'arredo del bagno in materiali non ferrosi.

Certified management system by ICIM

This certification is valid for the following application field:
Design and manufacture of handles, furniture coordinated accessories and bathroom furniture accessories in non-ferrous materials.



UNI EN ISO 14001

Sistema di gestione certificato da ICIM

Questa certificazione è valida per il seguente campo applicativo:
Progettazione e fabbricazione di maniglie e complementi per arredamento in materiale non ferroso, accessori per l'arredo del bagno mediante le fasi di: pressofusione, burattatura, pulitura, galvanica, verniciatura, assemblaggio, confezionamento ed immagazzinamento.

Certified management system by ICIM

This certification is valid for the following application field:
Design and manufacture of non-ferrous handles and coordinated furniture accessories, bathroom furniture accessories by: die-casting, tumble finishing, polishing, electroplating, varnishing, assembling, packing and storing.



UNI EN 1906

Nuova certificazione europea per le maniglie

La norma Europea UNI EN 1906 stabilisce requisiti e metodi di prova per maniglie e pomoli.
Colombo Design ha conseguito, per tutti i suoi modelli, lusinghieri risultati tra i quali il più significativo è il "Grado 4" per la categoria d'uso: sinonimo di assoluta qualità e resistenza.

New European certification for door furniture

The European standard UNI EN 1906 establishes requirements and test methods for lever handles and knobs.
Colombo Design achieved, for all of its models, excellent results between which the most significant is the "Grade 4" for the category of use: synonym of absolute quality and resistance.

Warranties.



trattamento di protezione garantito 30 anni

Quello utilizzato da Colombo Design è un processo di finitura mutuato dal settore dell'utensileria, in cui caratteristiche fisiche e meccaniche sono studiate per garantire prestazioni eccezionali di resistenza all'usura meccanica e al decadimento dovuto ad agenti ambientali e chimici. Il processo è stato messo a punto per garantire un notevole aspetto estetico, trasparenza e lucentezza, che fanno risaltare il design del prodotto. Tutti i prodotti trattati con il processo PVD, vengono preventivamente rivestiti con strati di rame, nichel e cromo per garantire un perfetto isolamento della materia prima sottostante. Trattamento con la garanzia di "30 anni" sulle finiture **Zirconium Gold, Oromat, Zirconium Stainless-Steel, Vintage, Vintage Mat, Grafite e Grafite Mat.**



trattamento di protezione garantito 10 anni

La lunga esperienza maturata nel settore dei trattamenti galvanici e PVD, unita alla scelta di prestare particolare attenzione alla qualità nei processi produttivi, consentono a Colombo Design di garantire le finiture dei suoi prodotti oltre la normale copertura prevista dalla legge. È quindi con particolare orgoglio che offriamo ai nostri utenti la garanzia di "10 anni" sulle finiture **Oroplus, Cromo, Cromat, Biancomat e Neromat.** Questo impegno di durata nel tempo del prodotto è la nostra forte ed alternativa risposta al consumismo «usa e getta», sinonimo di spreco ambientale e nemico della memoria collettiva, irrinunciabile valore di tutte le società.

treatment protection guaranteed 30 years

Colombo Design uses a finishing process borrowed from the tools industry, where physical and mechanic features have to guarantee a very high performance as far as mechanic wear and decay due to environmental and chemical agents are concerned. This finishing process also guarantees a high level of design where transparency and brightness allow the product to reveal. All PVD-treated products with High Protection System finishing are previously coated with layers of copper, nickel and chrome in order to guarantee the perfect insulation of the underlying raw material. Treatment with warranty of "30 years" on **HPS Zirconium Gold, Matt Gold, HPS/I Zirconium Stainless-Steel, Vintage, Vintage Mat, Graphite and Matt Graphite** finishing.

treatment protection guaranteed 10 years

The long experience in the field of galvanic treatments, combined with the choice to pay special attention to the quality in production processes, enable Colombo Design to ensure the finishes of its products beyond the normal warranty provided by law. It is therefore with great pleasure, we offer to our end-users the warranty of "10 years" on **Oroplus, Chrome, Matt chrome, Matt white and Matt black** finishings. This commitment of product durability is our strong and alternative response to consumerism «disposable», synonymous with environmental waste and enemy of collective memory, an essential value of all societies.

Innovations.



ZERO EVOLUTION

L'innovativo sistema di Colombo Design.
Le maniglie per porte e finestre con meno ingombro,
più minimal e più eleganza.

UNI EN 1906 (maniglie per porta)
Maniglie zero evolution, le prime con molla di ritorno.
Durabilità: grado 7 - garantite per elevata frequenza
d'uso - minimo 200.000 cicli.

UNI EN 13126-3 (solo per maniglie da finestra)
Certificazione di durabilità garantita per minimo
25.000 cicli, ciascuno con sequenza:
0°-90°-180°-90°-0°

Colombo Design's innovative system.
Door and window handles with less space,
more minimalism and more elegance

UNI EN 1906 (door handles)
Zero evolution handles, the first ONES with return
spring. Durability: GradeE 7 - guaranteed for high
requeency of use - minimum 200.000 cycles.

UNI EN 13126-3 (window handles)
Durability certification guaranteed for a minimum
of 25.000 cycles, each one with sequence:
0°-90°-180°-90°-0°.



SIX MILLIMETERS CONCEPT

Maniglie con rosetta e bocchetta bassa che non
necessitano di lavorazioni aggiuntive sulla porta.

Handles with slim rose and escutcheon.
They don't need additional installation works
on the door.



ROBOTECH®

Robotech® contraddistingue una gamma di prodotti
realizzata utilizzando alta tecnologia e massima
automazione per ottenere eccellenza qualitativa e
commerciale.

Robotech® is our mark for those products manufactured
using high technologies and ultimate automation,
to create quality and trading excellence.



CASA SICURA

La soluzione per vivere in una casa sicura.
Se vuoi avere la sicurezza di vivere in un ambiente
tranquillo e sereno, affidati al sistema antintrusione di
Colombo Design!
Il pulsante blocca maniglia ne impedisce la rotazione,
di conseguenza i malintenzionati non riusciranno
più ad entrare nelle vostre case passando dalle finestre
e dalle porte finestre.

SAFE HOUSE

The right solution for a safe house. If you're looking
for a safe feeling while being in your home, you should
use the Colombo Design Security System!
The button locks the handle preventing the rotation,
so bad people won't be able to enter your house,
not via the doors nor the windows.

Production process and finishings.

materiali

- OTTONE
- CROMALL®

ciclo standard trattamento galvanico

- OTTONE e/o CROMALL® leghe metalliche con qualità certificata
- strato di pre-rame elettrodeposto
- secondo strato di rame elettrodeposto
- strato livellante di NICHEL elettrodeposto ad altissimo spessore
- strato elettrodeposto OROPLUS, CROMO e CROMAT
- trattamento PVD solo per finiture
HPS ZIRCONIUM GOLD,
HPS ZIRCONIUM STAINLESS-STEEL, OROMAT,
VINTAGE, VINTAGE MAT, GRAFITE e GRAFITE MAT

materials

- SOLID BRASS
- CROMALL®

standard galvanic treatment cycle

- SOLID BRASS and/or CROMALL® metal alloys of certified quality
- first electroplated copper layer
- second electroplated copper layer
- very high electroplated NICKEL levelling layer
- electroplated layer OROPLUS, CHROME and MATT CHROME
- PVD treatment applicable only on finishings
HPS ZIRCONIUM GOLD,
HPS ZIRCONIUM STAINLESS-STEEL, MATT GOLD,
VINTAGE, VINTAGE MAT, GRAPHITE and MATT GRAPHITE

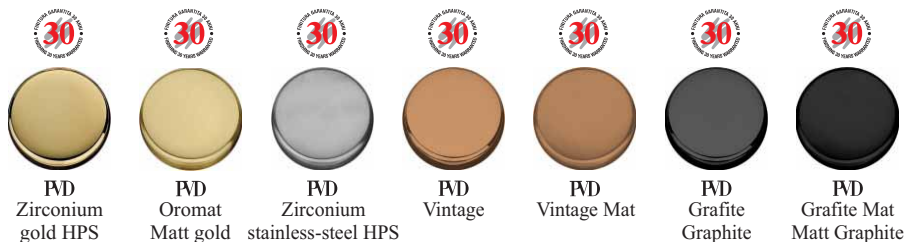
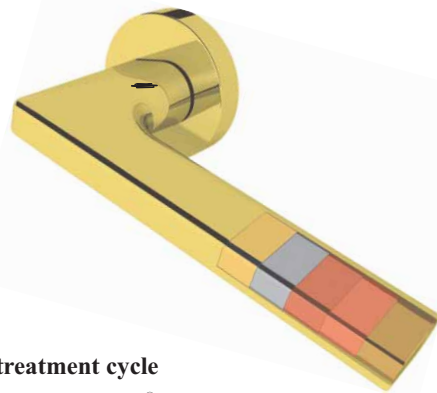

PVD treatment.



Trattamento Pvd, ispirato dai nuovi colori di tendenza.

Il trattamento PVD (Physical Vapor Deposition) è un processo di altissimo livello tecnologico che, mediante deposizione fisica da vapore di una sottile pellicola di straordinaria durezza, permette di ottenere un rivestimento superficiale dalle eccezionali caratteristiche estetiche e tecniche. Una tecnologia utilizzata per offrire tonalità cromatiche stabili nel tempo e per garantire prodotti con elevata durezza superficiale, inalterabilità ai raggi UV, resistenza all'usura, all'abrasione e alla corrosione. Garantito 30 anni e realizzato internamente negli stabilimenti produttivi Colombo Design mediante l'utilizzo di una speciale macchina, il trattamento PVD è disponibile nelle finiture Oromat, Zirconium Gold, Zirconium stainless-steel, Vintage, Vintage Mat, Grafite e Grafite Mat.



Pvd treatment, be inspired by new trending colors.

PVD (Physical Vapor Deposition) treatment is a process of the highest technological level which allows to obtain a surface coating with exceptional aesthetic and technical characteristics through physical vapor deposition of a thin film of extraordinary hardness. A technology used to offer stable color tones over time and to guarantee products with high surface hardness, inalterability against UV rays, resistance to wear and corrosion. 30 years warranted and obtained internally in the Colombo Design production plants using a special machine, the PVD treatment is available in Oromat, Zirconium Gold, Zirconium stainless-steel, Vintage, Vintage Mat, Graphite and Matt Graphite finishes.

Designers.

Ogni cosa è stata disegnata.
Poche cose sono state disegnate bene.

Everything is designed.
Few things are designed well.

ACERBIS, Marco
ANDREA MAFFEI ARCHITECTS
ANGELETTI RUZZA DESIGN
ARCHITETTURA LABORATORIO
BARTOLI DESIGN
BETTONICA, Luta e LEONE, Giancarlo
CASTRIGNANO, Andrea
CLAESSON KOIVISTO RUNE
COLOMBO, Luca
DE LUCCHI, Michele
DI BLASI, Ottavio
GRCIC, Konstantin
HASUIKE, Makio
KIMURA, Tomo
JOUIN, Patrick
LOHMANN, Birgit
LUCCHESI, Francesco
MASSAUD, Jean Marie
MEDA, Alberto
MESSINEO e SETTIMELLI
CATTANEO, Paolo ( DESIGN)
MICK & LUKE
MORRISON, Jasper
PININFARINA, Paolo
PIO e TITO TOSO lab
PIVA, Marco
RAGNI, Matteo
RONCHI, Mauro
STUDIO KAIROS
STUDIO JEAN-PHILIPPE NUEL
STUDIO SPALVIERI / DEL CIOTTO



Colombo Design apre all'arte, alla storia e alla cultura unendo alla tradizione ciò che più le appartiene: il design. Il connubio con Accademia Carrara ha lo scopo di diffondere la bellezza della creatività italiana in tutto il mondo, offrendo un incontro di valori che stabilisce una forte connessione tra emozioni e comunicazione, tra talento e abilità, tra interpretazione e comprensione del sentiment di artisti e designers. OPEN ART racconta l'arte e il design con le maniglie di Colombo Design.

Colombo Design opens the door to art, history and culture by linking tradition with what most belongs to it: design. The partnership with Accademia Carrara aims to spread the beauty of Italian creativity around the world, offering a meeting of values that establishes a strong connection between emotions and communication, between talent and skill, between interpretation and understanding of the sentiment of artists and designers. OPEN ART talks about art and design with handles by Colombo Design.



design partner



Maniglia per Porta
Door handle
Mood CC11 R
Strawberry Red
2011
mood

Raffaello Sanzio
San Sebastiano
Saint Sebastian
Tempera e olio su tavola
Tempers and oil on panel
1502 - 1503 ca.



Maniglia per Porta
Door handle
Ama MF11 RY
Cromo
Chrome
2018

Pseudo Giovanni
San Bonaventura docente
Saint Bonaventure Teaching
Olio su tavola
Oil on panel
1520 ca.



Maniglia per Porta
Door handle
Electra MS11 R
Vetraggio mat
2013

Giovanni Battista Moroni
**Ritratto di una bambina
di casa Redetti**
*Portrait of a Girl
of the Redetti Family*
Ciao in tela
Oil on canvas
1570-1572



Maniglia per Porta
Door handle
Twitty TK11 RY
Cromat
Matt chrome
2012

Piccio (Giovanni Carnovali)
**Ritratto della contessa
Anastasia Spini**
*Portrait of Countess
Anastasia Spini*
Olio su tela
Oil on canvas
1640 ca.



Collections.

ZERO
EVOLUTION



- 20 **maniglie per porta** door handles
- 24 **maniglie per finestra** Dreh kipp handles
- 28 **maniglioni per alzanti scorrevoli** pull-up handles
- 30 **bocchette e nottolini** escutcheons and toilet roses

mood

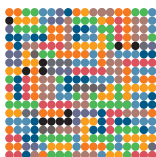

- 37 **One / OneQ**

le collezioni
the collections



- | | | | |
|---------------------|-----------------------|------------------------|-------------------|
| 65 _963 | 135 fedra | 203 pegaso | 273 twitty |
| 69 _peak | 139 flessa | 207 prius | 277 viola |
| 73 alatò | 143 gaia | 211 sirio | 281 wing |
| 77 alba | 147 gira | 217 slim | 285 zelda |
| 81 ama | 151 isy | 221 spider MR11 | |
| 85 blazer | 157 lara | 225 spider MR15 | |
| 89 bold PT11 | 161 libra | 229 star | |
| 93 bold PT15 | 165 lund | 233 tacta | |
| 97 daytona | 171 madi | 237 tailla | |
| 101 dea | 175 mapo | 241 taipan | |
| 105 drop | 179 meta | 245 talita | |
| 109 edo | 183 milla LC31 | 249 tecno | |
| 113 electra | 187 milla LC41 | 253 tender | |
| 119 elle | 191 mixa | 257 tool | |
| 125 ellesse | 195 moon | 265 trama LC71 | |
| 131 esprit | 199 olly | 269 trama LC81 | |

Classic Line



- 293 **cameo**
- 297 **heidi**
- 301 **ida**
- 305 **peter**
- 309 **piuma**

ROBOTECH®



- 317 **mach**
- 321 **robot CD41**
- 325 **robot CD75**
- 329 **robodue**
- 333 **robotre**
- 337 **roboquattro**
- 341 **roboquattros**
- 345 **robocinque**
- 349 **robocinques**

pomoli
door knobs



356 bold	366 etro	376 robot CD55	386 spider
358 cut MS15	368 mapo	378 robot CD65	388 square LC15
360 cut MS25	370 moon	380 robot CD75	390 square LC25
362 daytona	372 push	382 round ID25	392 square LC35
346 drop	374 robot CD45	384 round ID35	

maniglioni e battenti
pulls and door knockers



396 daytona	412 roboquattro	428 nice	438 am113-213y	452 cd213rs-lc413rs
398 elle	414 square	430 piuma	440 id113-213y	454 id313rs-id513rs
400 five	416 tender	432 robot	442 id313-413y	
402 flesso	418 wave	434 cloud	444 id513-613y	
404 logo	420 zen	436 wind	446 lc113-213y	
406 lund	424 blues	456 flessum	448 lc413-513y	
408 noa	426 jazz	458 toc-toc	450 cd113 mignon	

maniglioni per alzante scorrevole
pull-up handles for sliding doors

maniglie ad incasso
flush handles



462 enter	470 cd311
464 open	470 cd511
466 open sq	472 cb111
468 cd111	474 id411
468 cd211	476 lc111

programma blindate
armored door program



480 mostrine	rose plates
484 inserti	universal underconstructions
486 mostrine	rose plates
490 pomolini	knob sets
492 kit sr	sr kit

complementi
complements



496 dispositivi antieffrazione	windows security sets
498 dispositivi di sicurezza	windows security sets
500 fermaporta	door stoppers
502 chiavi	keys
504 nottolini	toilet roses
508 libero/occupato	toilet roses with privacy snibs

appenditutto
coat hangers



512 alizé	526 hook 1/2	540 mini	554 trenta
514 bart	528 khala	542 nordic	556 trio
516 basic	530 land	544 over	
518 basic Q	532 link	546 plus	
520 club	534 look	548 portofino	
522 forever	536 lulù	550 road	
524 hermitage	538 melò	552 time	

FORMAE®



560 maniglie per mobile	furniture handles
586 pomoli per mobile	furniture knobs



ZERO
EVOLUTION



COLOMBO
DESIGN

SI METTE
DAVANTI
AI PRIMI,
HA RAGIONE,
E' UNO
ZERO.

STANISLAW JERZY LEC

THE ONE
WHO PUTS HIMSELF
BEFORE THE FIRST,
IS RIGHT,
HE IS
A ZERO.

MANIGLIE PER PORTA
DOOR HANDLES



MANIGLIE PER FINESTRA
DREH KIPP HANDLES



MANIGLIONI PER
ALZANTI SCORREVOLI
PULL-UP HANDLES



BOCCHETTE E NOTTOLINI
ESCUTCHEONS
AND TOILET ROSES



ZERO EVOLUTION

**L'INNOVATIVO SISTEMA DI COLOMBO DESIGN.
LE MANIGLIE PER PORTE E FINESTRE
CON MENO INGOMBRO, PIÙ MINIMAL
E PIÙ ELEGANZA.**

**COLOMBO DESIGN'S INNOVATIVE SYSTEM.
DOOR AND WINDOW HANDLES
WITH LESS SPACE, MORE MINIMALISM
AND MORE ELEGANCE.**

MANIGLIE PER PORTA
DOOR HANDLES



ALATO' JP11 RSB/O GM GRAFITE MAT / MATT GRAPHITE



AMA MF11 RSB/O CM CROMAT / MATT CHROME



DEA FF21 RSB/O CR CROMO / CHROME



GIRA JM11 RSB/O VM VINTAGE MAT



TOOL MD11 RSB/O CR CROMO / CHROME



ZELDA MM11 RSB/O CM CROMAT / MATT CHROME

UNI EN 1906

MANIGLIE ZERO EVOLUTION,
LE PRIME CON MOLLA DI RITORNO.
DURABILITA': GRADO 7 - GARANTITE PER ELEVATA
FREQUENZA D'USO - MINIMO 200.000 CICLI.

ZERO EVOLUTION HANDLES
THE FIRST ONES WITH RETURN SPRING.
DURABILITY: GRADE 7 - GUARANTEED FOR HIGH
FREQUENCY OF USE - MINIMUM 200.000 CYCLES.







MANIGLIE PER PORTA
DOOR HANDLES



ELLESSE **BD21 RSB/O** CM CROMAT / MATT CHROME



ROBOTRE **CD91 RSB/O** OL OROPLUS



ROBOQUATTRO **ID41 RSB/O** OM OROMAT / MATT GOLD



ROBOQUATTRO S **ID51 RSB/O** CM CROMAT / MATT CHROME



ROBOCINQUE **ID61 RSB/O** BM BIANCOMAT / MATT WHITE RAL 9016



ROBOCINQUE S **ID71 RSB/O** NM NEROMAT / MATT BLACK RAL 9005

UNI EN 1906

MANIGLIE ZERO EVOLUTION,
LE PRIME CON MOLLA DI RITORNO.
DURABILITA': GRADO 7 - GARANTITE PER ELEVATA
FREQUENZA D'USO - MINIMO 200.000 CICLI.

ZERO EVOLUTION HANDLES
THE FIRST ONES WITH RETURN SPRING.
DURABILITY: GRADE 7 - GUARANTEED FOR HIGH
FREQUENCY OF USE - MINIMUM 200.000 CYCLES.



MANIGLIE PER FINESTRA
DREH KIPP HANDLES



ALATO
JP12 DKO/SM
CM CROMAT / MATT CHROME



AMA
MF12 DKO/SM
CR CROMO / CHROME



DEA
FF22 DKO/SM
CM CROMAT / MATT CHROME



GIRA
JM12 DKO/SM
OL OROPLUS



TOOL
MD12 DKO/SM
CM CROMAT / MATT CHROME



ZELDA
MM12 DKO/SM
CR CROMO / CHROME

UNI EN 13126-3

CERTIFICAZIONE DI DURABILITÀ
GARANTITA PER MINIMO 25.000 CICLI,
CIASCUNO CON SEQUENZA:
0-90°-180°-90°-0°

DURABILITY CERTIFICATION GUARANTEED
FOR A MINIMUM OF 25.000 CYCLES,
EACH ONE WITH
0-90°-180°-90°-0° SEQUENCE.

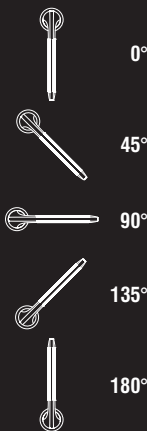





MANIGLIE PER FINESTRA
DREH KIPP HANDLES



ELLESSE
BD22 DKO/SM
CR CROMO / CHROME



ROBOTRE
CD92 DKO/SM
CM CROMAT / MATT CHROME



ROBOQUATTRO
ID42 DKO/SM
CM CROMAT / MATT CHROME



ROBOQUATTRO S
ID52 DKO/SM
VM VINTAGE MAT



ROBOCINQUE
ID62 DKO/SM
OL OROPLUS



ROBOCINQUE S
ID72 DKO/SM
GM GRAFITE MAT / MATT GRAPHITE

UNI EN 13126-3

CERTIFICAZIONE DI DURABILITÀ
GARANTITA PER MINIMO 25.000 CICLI,
CIASCUNO CON SEQUENZA:
0-90°-180°-90°-0°

DURABILITY CERTIFICATION GUARANTEED
FOR A MINIMUM OF 25.000 CYCLES,
EACH ONE WITH
0-90°-180°-90°-0° SEQUENCE.



MANIGLIONI PER
ALZANTI SCORREVOLI
PULL-UP HANDLES



FORME PULITE E MINIMALISMO FUNZIONALE
PER LASCIARE SPAZIO ALL'ESTETICA
DELL'ALZANTE SCORREVOLE. LA SEMPLICITÀ
SOFISTICATA NEL DETTAGLIO TECNICO.

CLEAN FORMS AND FUNCTIONAL MINIMALISM
TO LEAVE ROOM FOR THE AESTHETICS OF THE
LIFT&SLIDE. SOPHISTICATED SIMPLICITY IN
TECHNICAL DETAIL.



ID113/O
OL OROPLUS



LC113/O
CM CROMAT / MATT CHROME



ID313/O
VM VINTAGE MAT



ID313Q/O
CM CROMAT / MATT CHROME



ID513/O
NM NEROMAT / MATT BLACK
RAL 9005



ID513Q/O
GM GRAFITE MAT / MATT GRAPHITE







ELEGANZA DI UN PARTICOLARE.
LE BOCCHETTE DELLA COLLEZIONE
ZERO EVOLUTION NELLA VERSIONE SIA YALE
CHE PATENT APRONO A UNO STILE MINIMAL.

ELEGANCE OF A DETAIL.
THE ESCUTCHEONS OF THE ZERO EVOLUTION
COLLECTION IN BOTH YALE AND PATENT
VERSIONS OPEN UP TO A MINIMALIST STYLE.



ZE13 BB/O (PAT)

ZE23 BB/O (PAT)

ZE13/O (Y)

ZE23/O (Y)



**I NOTTOLINI ZERO EVOLUTION SONO
UN'ELEGANTE SOLUZIONE PER UN
RAFFINATO MINIMALISMO NELLE PORTE.**

**ZERO EVOLUTION KNOBS ARE AN
ELEGANT SOLUTION FOR REFINED
MINIMALISM IN THE DOORS.**



ZE19 BZG/O

ZE29 BZG/O



**MANIGLIE PER PORTA
DOOR HANDLES**

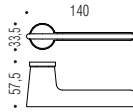

JP11 RSB/O
CR/CM/GM

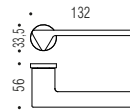

MF11 RSB/O
CR/CM/GM

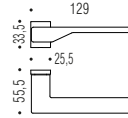

FF21 RSB/O
CR/CM

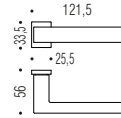

BD21 RSB/O
CR/CM

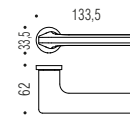

JM11 RSB/O
OL/CR/CM/YM

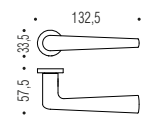

CD91 RSB/O
OL/OM/CR/CM

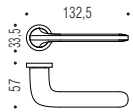

ID41 RSB/O
OL/OM/CR/CM

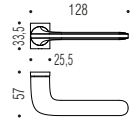

ID51 RSB/O
CR/CM/YM

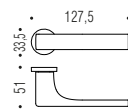

ID61 RSB/O
OL/CR/CM/NM/BM

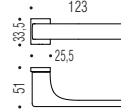

ID71 RSB/O
CR/CM/GM/NM/BM

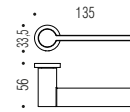

MD11 RSB/O
CR/CM

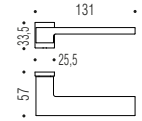

MM11 RSB/O
CR/CM

**BOCCHETTE
E NOTTOLINI
ESCUTCHEONS
AND TOILET ROSES**



ZE13 BB/O (PAT)
OL/OM/CR/CM/YM
GM/NM/BM



ZE13/O (Y)
OL/OM/CR/CM/YM
GM/NM/BM



ZE23 BB/O (PAT)
CR/CM/VL/NM/BM



ZE23/O (Y)
CR/CM/VL/NM/BM



ZE19 BZG/O
OL/OM/CR/CM/YM
GM/NM/BM



ZE29 BZG/O
CR/CM/VL/NM/BM

MANIGLIE PER FINESTRA
DREH KIPP HANDLES

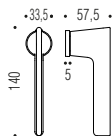

JP12 DKO/SM
CR/CM/GM

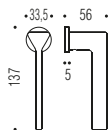

MF12 DKO/SM
CR/CM/GM

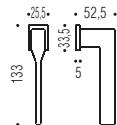

FF22 DKO/SM
CR/CM

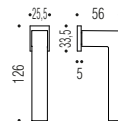

BD22 DKO/SM
CR/CM

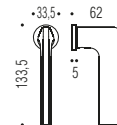

JM12 DKO/SM
OL/CR/CM/YM

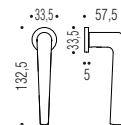

CD92 DKO/SM
OL/OM/CR/CM

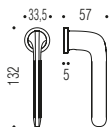

ID42 DKO/SM
OL/OM/CR/CM

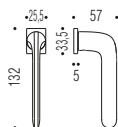

ID52 DKO/SM
CR/CM/YM

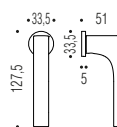

ID62 DKO/SM
OL/CR/CM/NM/BM

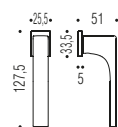

ID72 DKO/SM
CR/CM/GM/NM/BM

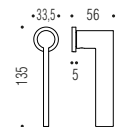

MD12 DKO/SM
CR/CM

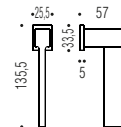

MM12 DKO/SM
CR/CM





MANIGLIONI PER
ALZANTI SCORREVOLI
PULL-UP HANDLES

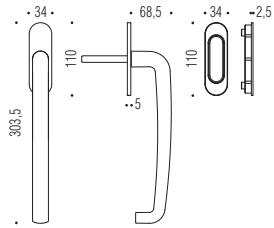

ID113/O
OL/OM/CR/CM

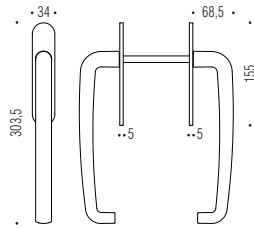

ID213 Y/O
OL/CM

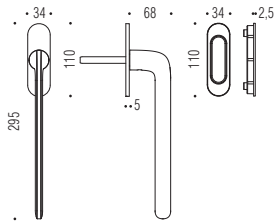

ID313/O
OL/OM/CR/CM/GM/YM

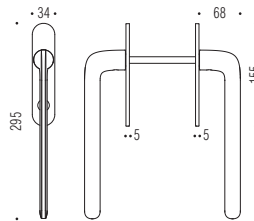

ID413 Y/O
OL/CM

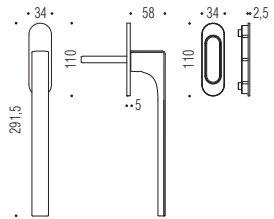

ID513/O
OL/CR/CM/GM/NM/BM

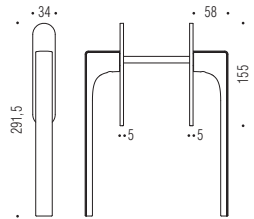

ID613 Y/O
CM/NM

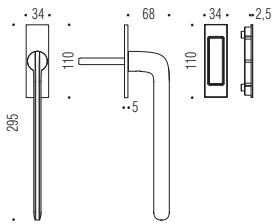

ID313 Q/O
CR/CM/YM

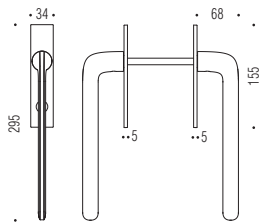

ID413 YQ/O
CR/CM

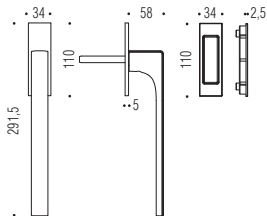

ID513 Q/O
CR/CM/GM/NM/BM

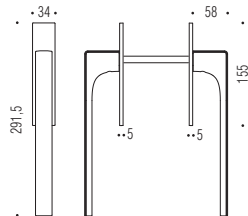

ID613 YQ/O
CR/CM/GM/NM

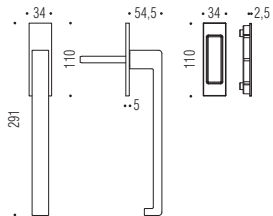

LC113/O
CR/CM

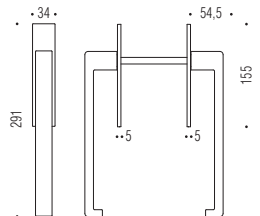

LC213 Y/O
CR/CM

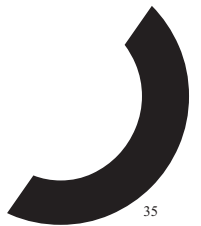



mood
C O L L E C T I O N





“One” e “OneQ” sono i primi
due modelli della collezione,
progettati da Colombo Design.

Maniglie dalle linee morbide e pulite, che
ben si prestano ad essere declinate in tutte
le varianti cromatiche RAL.

Nessun limite quindi alla creatività:
“ne facciamo di tutti i colori”!

“One” and “OneQ” are the first two models
of the collection, designed by Colombo Design.
Handles with soft and clean lines, which can be
easily declined in all RAL color variants.

So there is no limit to creativity:
“we are up to all sorts of things ... and colors”!

12 colori per 12 tappe significative di un viaggio lungo 30 anni e proiettato verso il futuro. Ripercorrendo la storia di Colombo Design dal 1990 al 2020, sono stati individuati gli anni che hanno segnato in modo determinante lo sviluppo aziendale, associando ad ognuno di essi un colore tra quelli proposti.

Dalla passione, competenza ed esperienza della famiglia Colombo nasce Colombo Design, un'azienda che pone al centro dei suoi prodotti qualità, estetica e funzionalità. Una family-company che infonde ai propri prodotti i valori e le tradizioni del saper fare italiano. Colombo Design was born from passion, competence and experience of the Colombo family, a company that puts quality, beauty and functionality at the center of its products. A family-company that creates its products with values and traditions of Italian know-how.

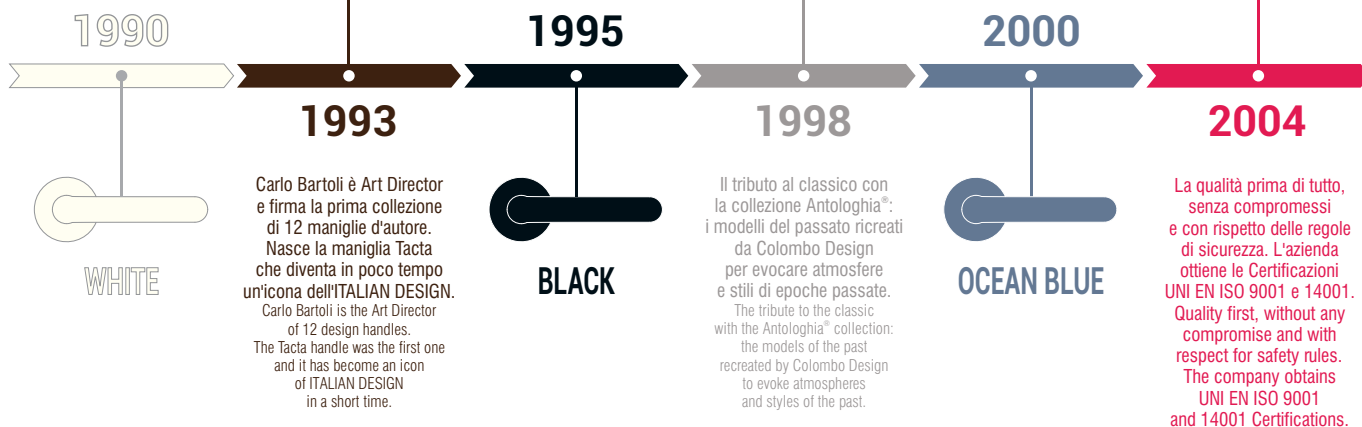

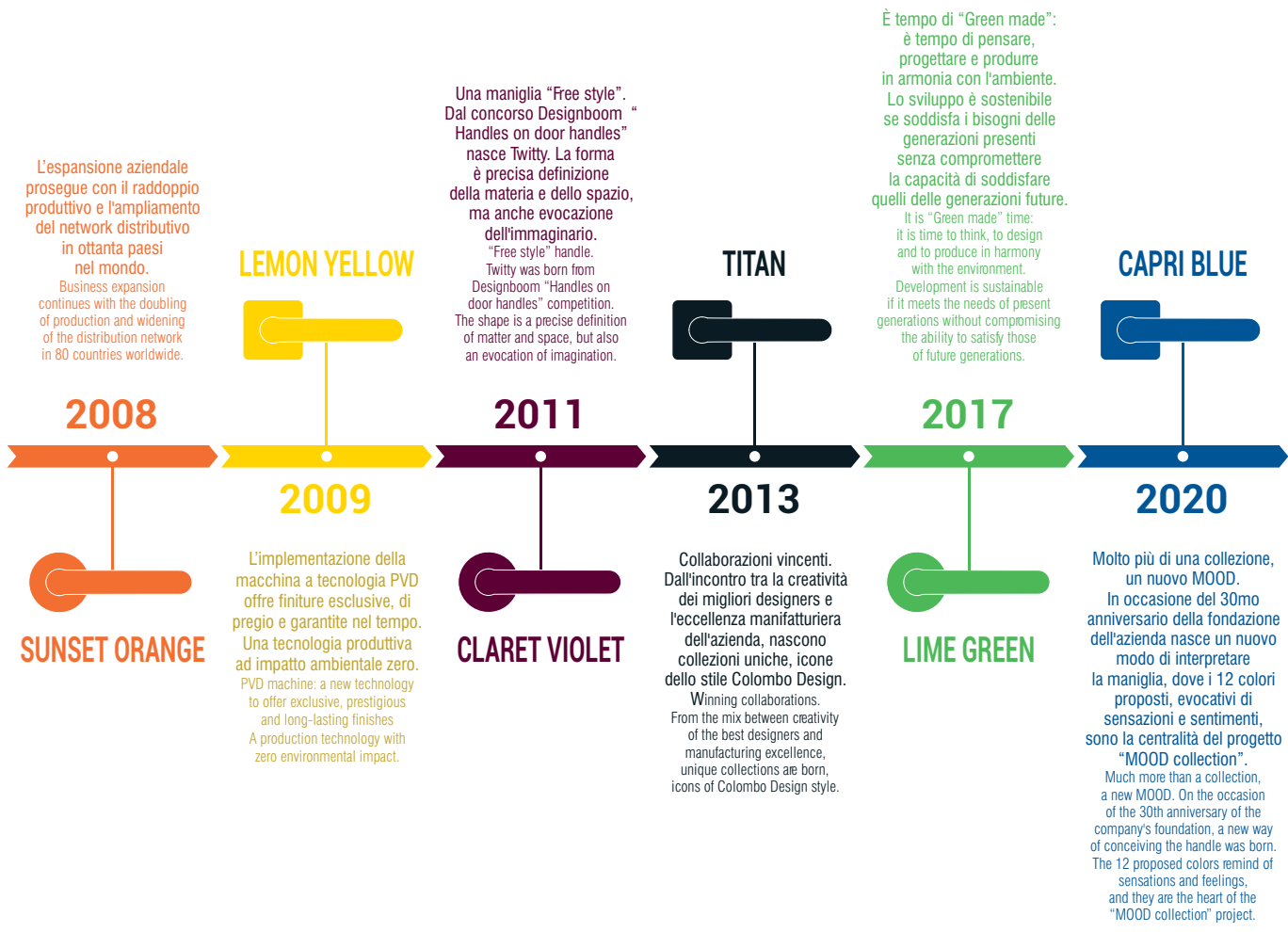

12 colors for 12 significant stages of a 30-year journey projected towards the future. Tracing the history of Colombo Design from 1990 to 2020, we have identified the years that have decisively marked our company's development, associating each of them with one color from those proposed.



MOOD Collection.
Molto più
di una collezione.

MOOD Collection.
Much more
than a collection.

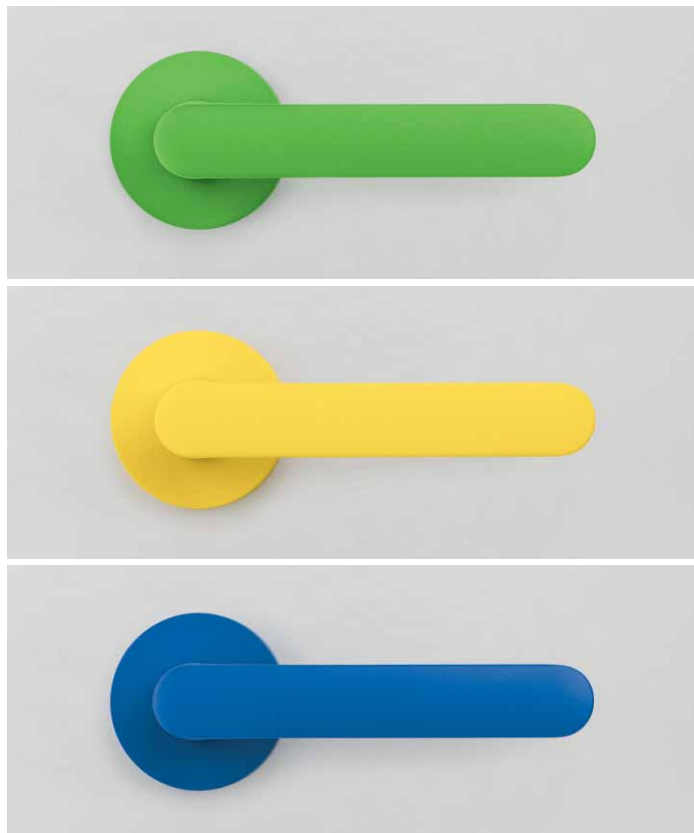

LIME GREEN
LEMON YELLOW
CAPRI BLUE

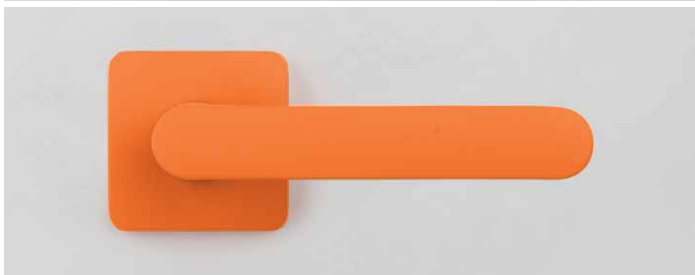
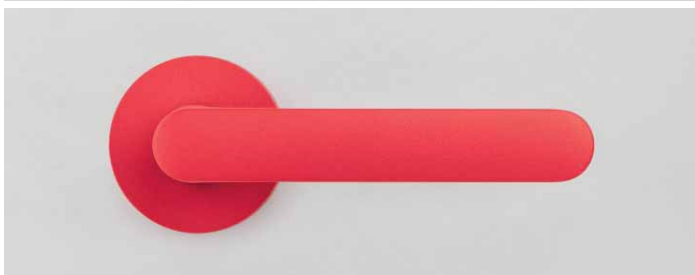
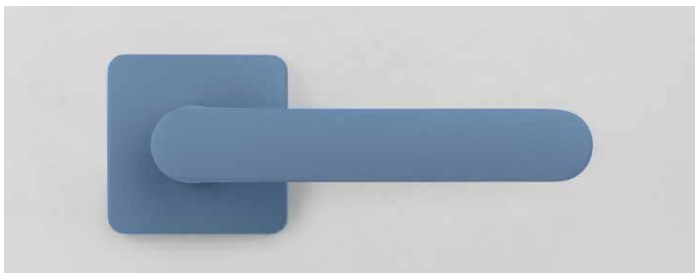

A disposizione una gamma di 12 colori, accuratamente selezionati per poter definire il *mood* di una stanza, così come lo stile di una porta o di un serramento attraverso accostamenti tono su tono o in contrasto.

A range of 12 colors is available, carefully selected to define the mood of an environment, as well as the style of a door or window through tone-on-tone or contrasting combinations.

OCEAN BLUE
STRAWBERRY RED
SUNSET ORANGE





MOOD Collection di Colombo Design dà spazio al colore e alla creatività. Un nuovo modo di presentare e interpretare la maniglia.

Protagonista è il colore, con la sua capacità di esprimere il *sentiment* di chi lo sceglie e di plasmare l'ambiente, arricchendolo di stimoli visivi che parlino delle persone che lo vivono.

Colombo Design's MOOD Collection gives space to color and creativity. A new way of presenting and conceiving the handle.

Color is the protagonist, with its ability to express the sentiment of those who choose it and to shape the environment, enriching it with visual stimulations from the people who live in this environment.



CLARET VIOLET
BRONZE
TITAN

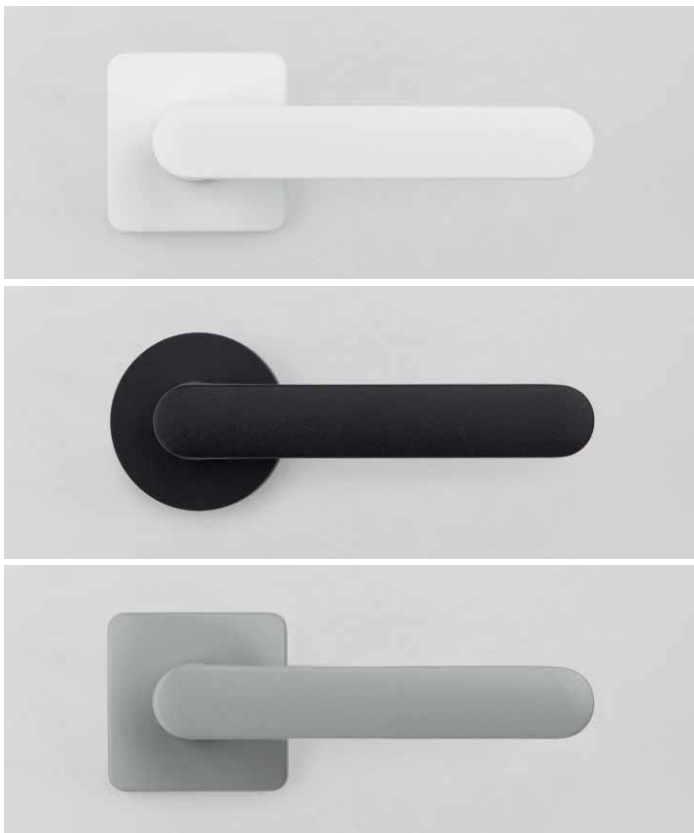

L'elevata qualità del materiale e l'utilizzo di vernici di ultima generazione sono espressione di un rinnovato impegno verso la tutela dell'ambiente e la riduzione dello spreco delle risorse, fattori che consentono di estendere la garanzia di questa collezione a 10 anni.

La gestione accurata dei processi produttivi è confermata dalla certificazione UNI EN ISO 14001 «Sistema di gestione ambientale certificato».

The high quality of the material and the use of latest generation paints are the expression of a renewed commitment to protecting the environment and reducing the waste of resources, factors that allow the warranty of this collection to be extended to 10 years.

The careful management of production processes is confirmed by the UNI EN ISO 14001 "Certified environmental management system" certification.

WHITE
BLACK
SILVER



Mood è la collezione multicolore di Colombo Design composta da maniglie per porte e finestre declinata in due versioni: One (rosetta e bocchetta tonda) e OneQ (rosetta e bocchetta quadrata).



WHITE / ONE
MANIGLIA SU ROSETTA
HANDLE ON ROSE



SILVER / ONEQ
MANIGLIA SU ROSETTA
HANDLE ON ROSE

Mood is the Colombo Design's multicolour collection of door and window handles available in two versions: One (round rose and key escutcheon) and OneQ (square rose and key escutcheon).

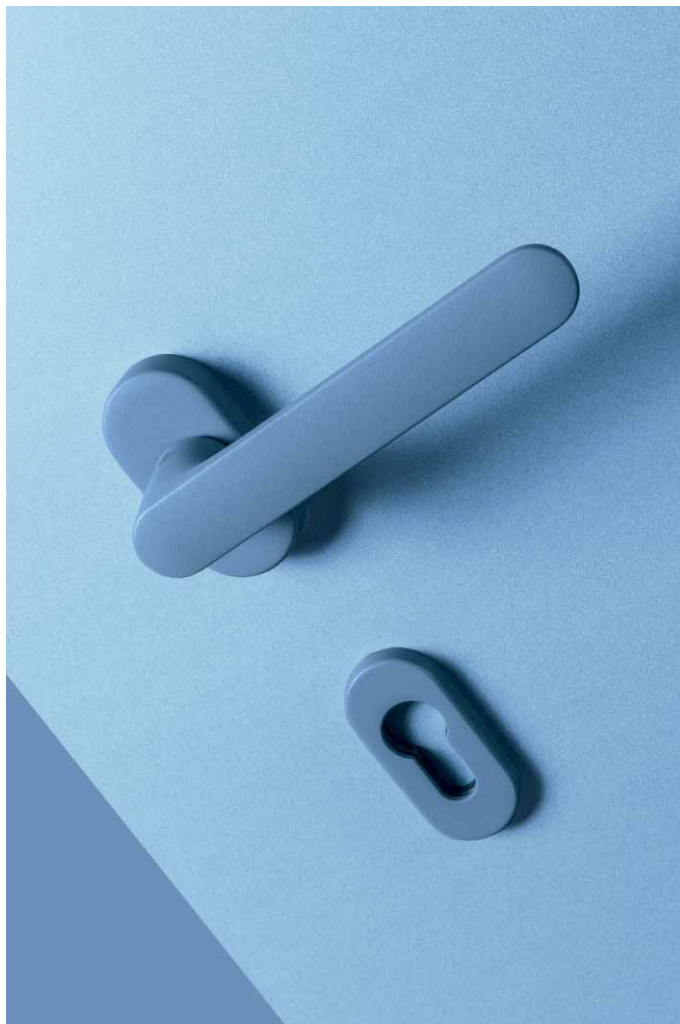

OCEAN BLUE / ONE
MANIGLIA SU ROSETTA STRETTA
HANDLE ON NARROW ROSE



BRONZE / ONEQ
MANIGLIA SU ROSETTA STRETTA
HANDLE ON NARROW ROSE

La maniglia per finestra e i pomoli per porta arricchiscono l'assortimento.
Dettagli che arredano e offrono uniformità estetica agli ambienti.

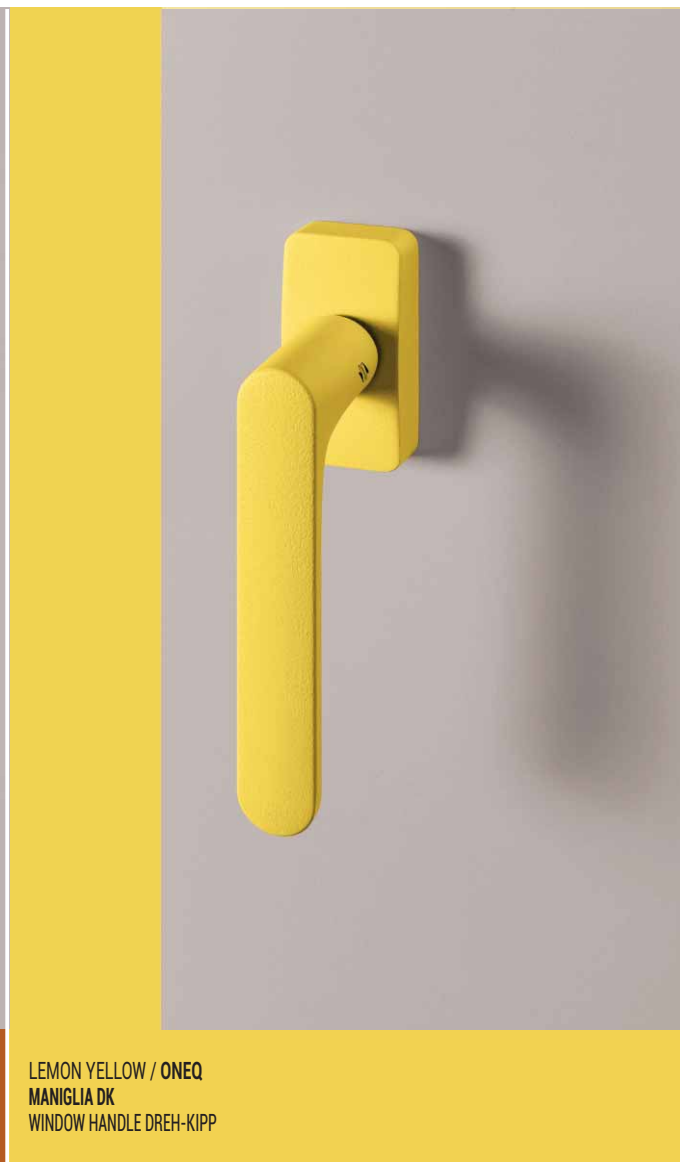

The window handle and the door knobs complete the assortment.
Details that furnish and offer aesthetic uniformity to the rooms.



OCEAN BLUE / ONE
POMOLO
DOOR KNOB



STRAWBERRY RED / ONEQ
POMOLO
DOOR KNOB

La collezione Mood include anche i maniglioni per porte e per alzanti scorrevoli e i kit per porte scorrevoli, declinati nelle due versioni tonda (One) e quadrata (OneQ). Elementi di design, che sottolineano lo stile, integrandosi con l'arredamento e donando carattere all'ambiente.

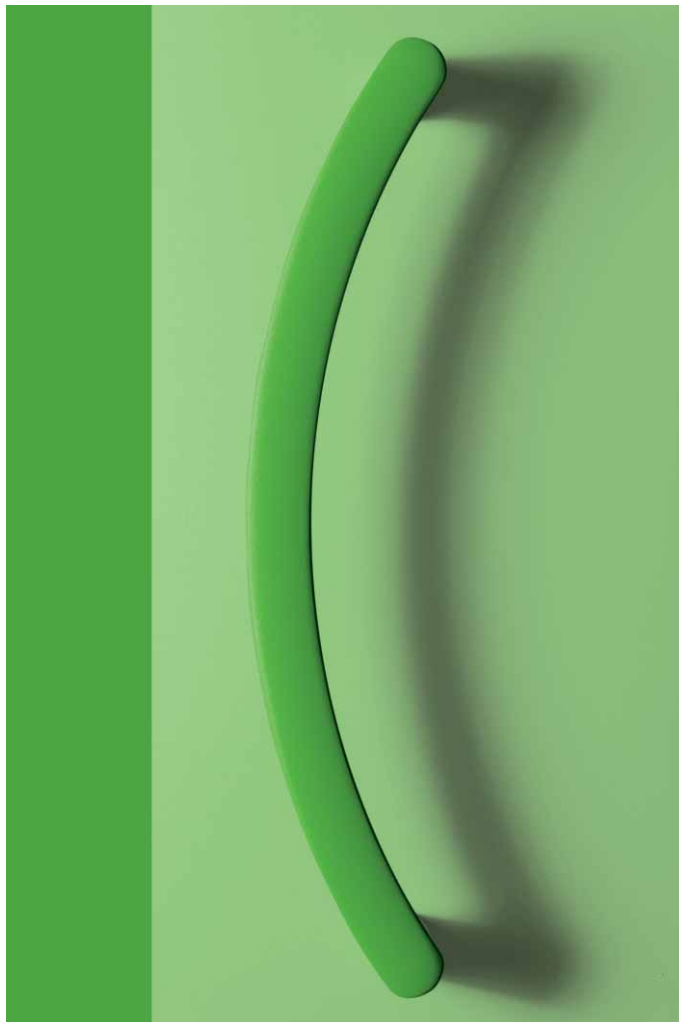

LIME GREEN / ONE - ONEQ
MANIGLIONE SENZA ROSETTE
PULL WITHOUT ROSES

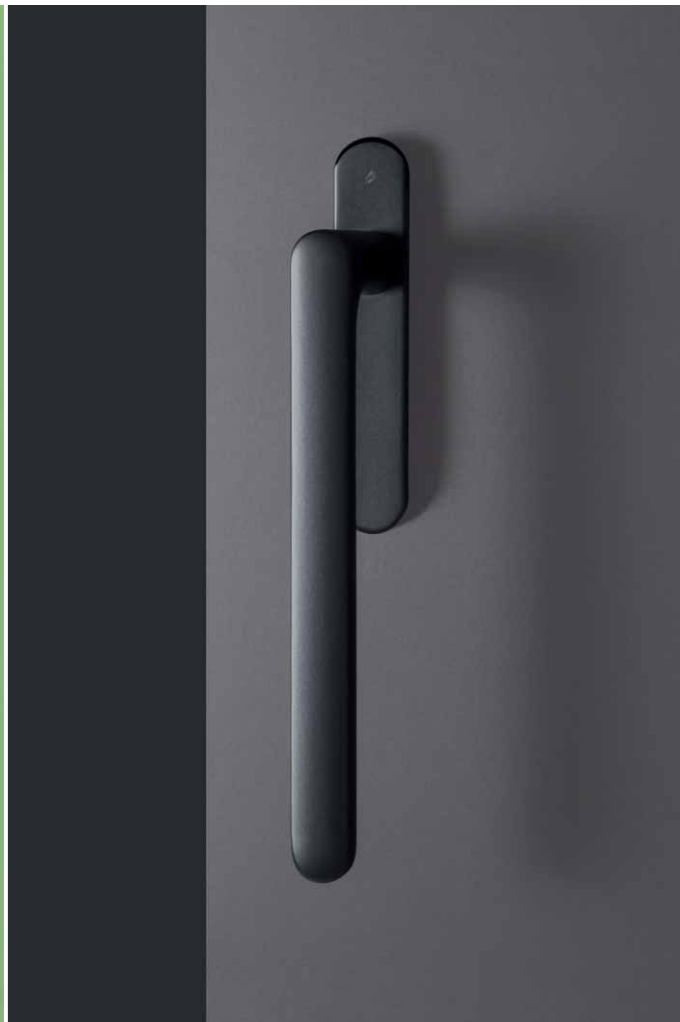

TITAN / ONE - ONEQ
MANIGLIONE PER ALZANTE SCORREVOLE
PULL-UP HANDLE FOR SLIDING DOORS

Our Mood collection includes pulls for doors and pull-up handles for sliding doors and sliding door kits, available on round (One) and square (One Q) version. Important design elements that emphasize the style by integrating with the furniture and by giving character to the environment.



BLACK / ONE
KIT PER PORTA SCORREVOLE COMPOSTO DA DUE MANIGLIE INCASSO
SLIDING DOOR KIT MADE OF TWO GROOVE HANDLES



WHITE / ONE
KIT PER PORTA SCORREVOLE - DUE MANIGLIE INCASSO - CHIUSURA A NOTTOLINO
SLIDING DOOR KIT - TWO GROOVE HANDLES - TOILET KNOB CLOSURE

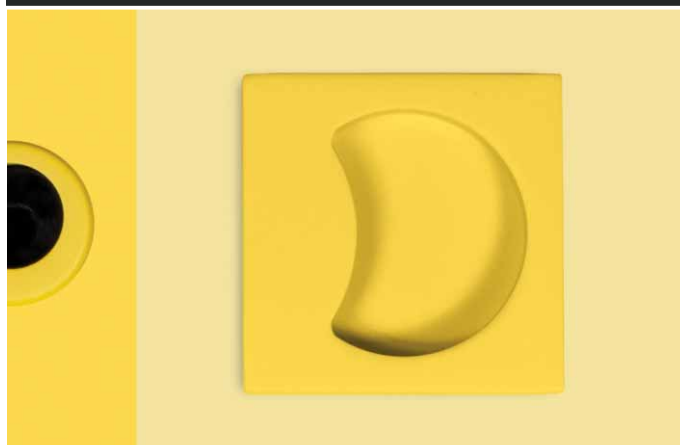

LEMON YELLOW / ONEQ
KIT PER PORTA SCORREVOLE COMPOSTO DA DUE MANIGLIE INCASSO
SLIDING DOOR KIT MADE OF TWO GROOVE HANDLES

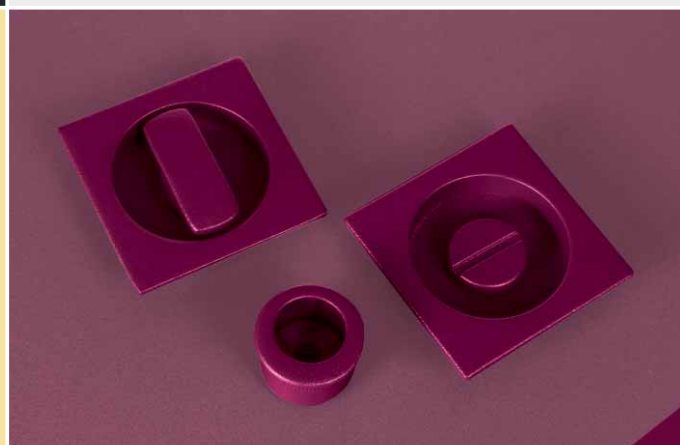

CLARET VIOLET / ONEQ
KIT PER PORTA SCORREVOLE - DUE MANIGLIE INCASSO - CHIUSURA A NOTTOLINO
SLIDING DOOR KIT - TWO GROOVE HANDLES - TOILET KNOB CLOSURE

Nottolini e kit per porte blindate, declinate nelle due versioni: tonda (One) e quadra (OneQ).
Stile e protezione si integrano armoniosamente nell'estetica degli spazi.



STRAWBERRY RED / ONE
NOTTOLINI
TOILET ROSES

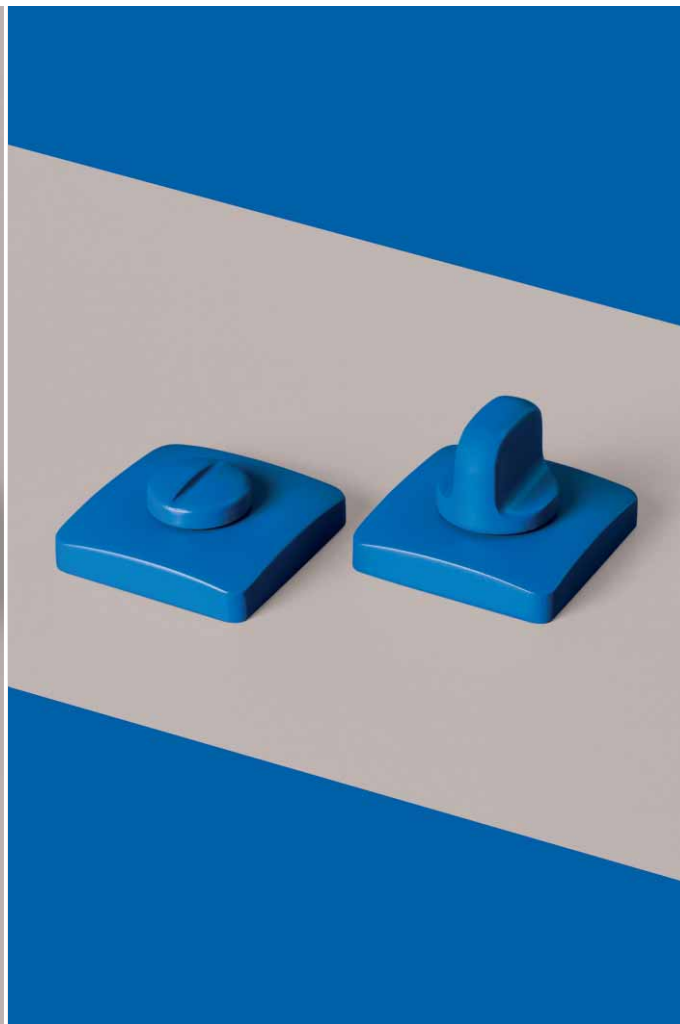

CAPRI BLUE / ONEQ
NOTTOLINI
TOILET ROSES

The toilet roses and kits for armoured doors, available in two versions: round (One) and square (OneQ). Style and protection integrate harmoniously into the aesthetics of living spaces.



SUNSET ORANGE / ONE
KIT PER PORTE BLINDATE
ARMoured DOOR KIT

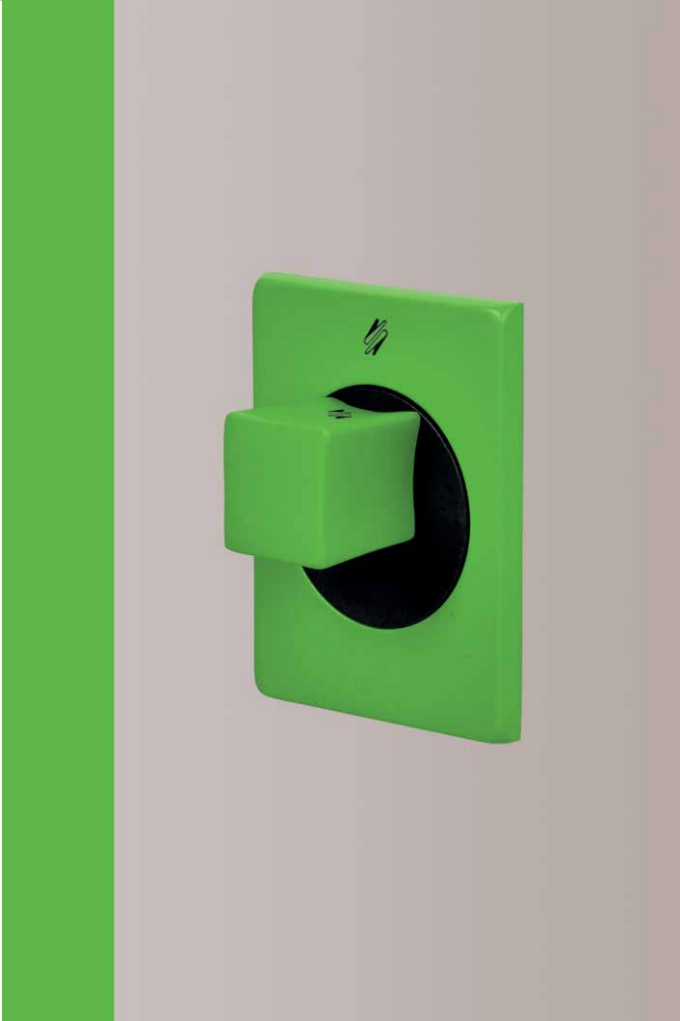

LIME GREEN / ONEQ
KIT PER PORTE BLINDATE
ARMoured DOOR KIT



WHITE / ONEQ



ONEQ / LIME GREEN



CLARET VIOLET / ONEQ



ONE / OCEAN BLUE



SUNSET ORANGE / ONEQ

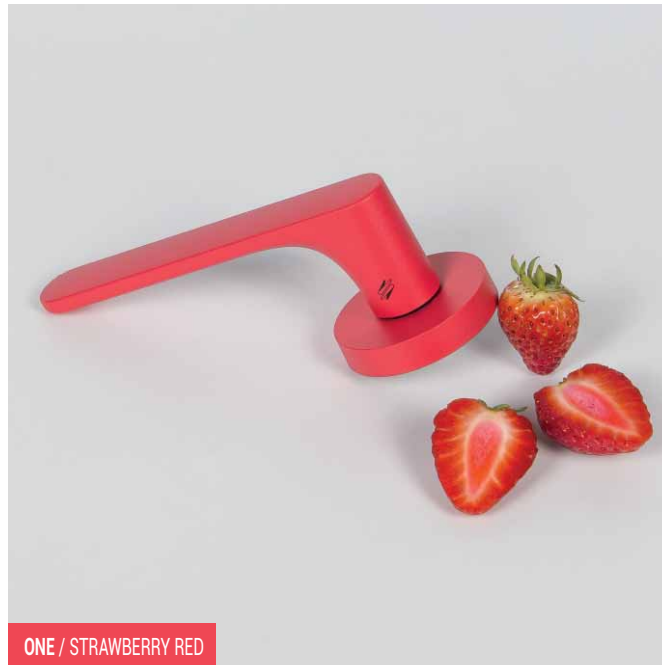

ONE / STRAWBERRY RED



LEMON YELLOW / ONE

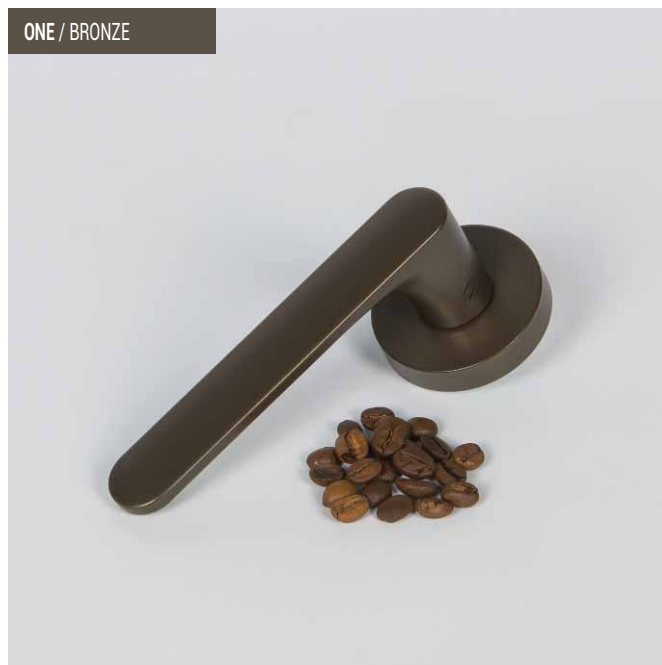

ONE / BRONZE

ONE

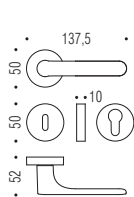

CC11 R-RY Ø50

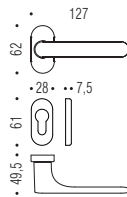

CC11 RSMY



CC19 BZG Ø50

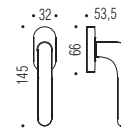

CC12 DK/SM

ONEQ

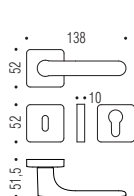

CC21 R-RY 52x52

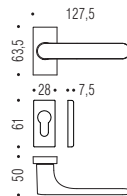

CC21 RSMY



CC29 BZG 52x52

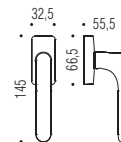

CC22 DK/SM

ONE ONEQ

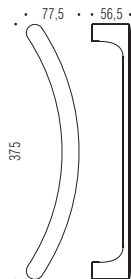

CC16

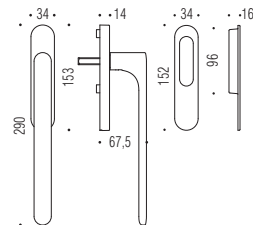

CC113



CC15 FISSO Ø50

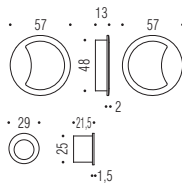

CC211

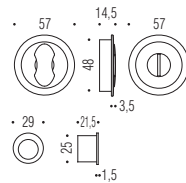

CC211 BZG

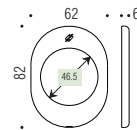

PB01

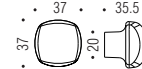

PB09

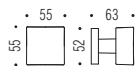

CC25 FISSO 52x52

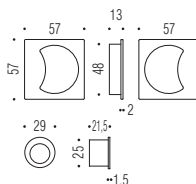

CC311

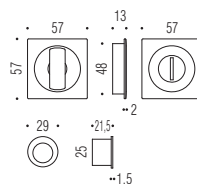

CC311 BZG

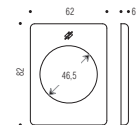

PB01Q

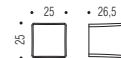

PB09Q

Ne facciamo di tutti i colori.
 We are up to all sorts of things ... and colors.



Per ulteriori informazioni consultare il listino prezzi. For additional information please refer to our price list.

2024 EDITION

Le Collezioni

The Collections

MADE IN ITALY

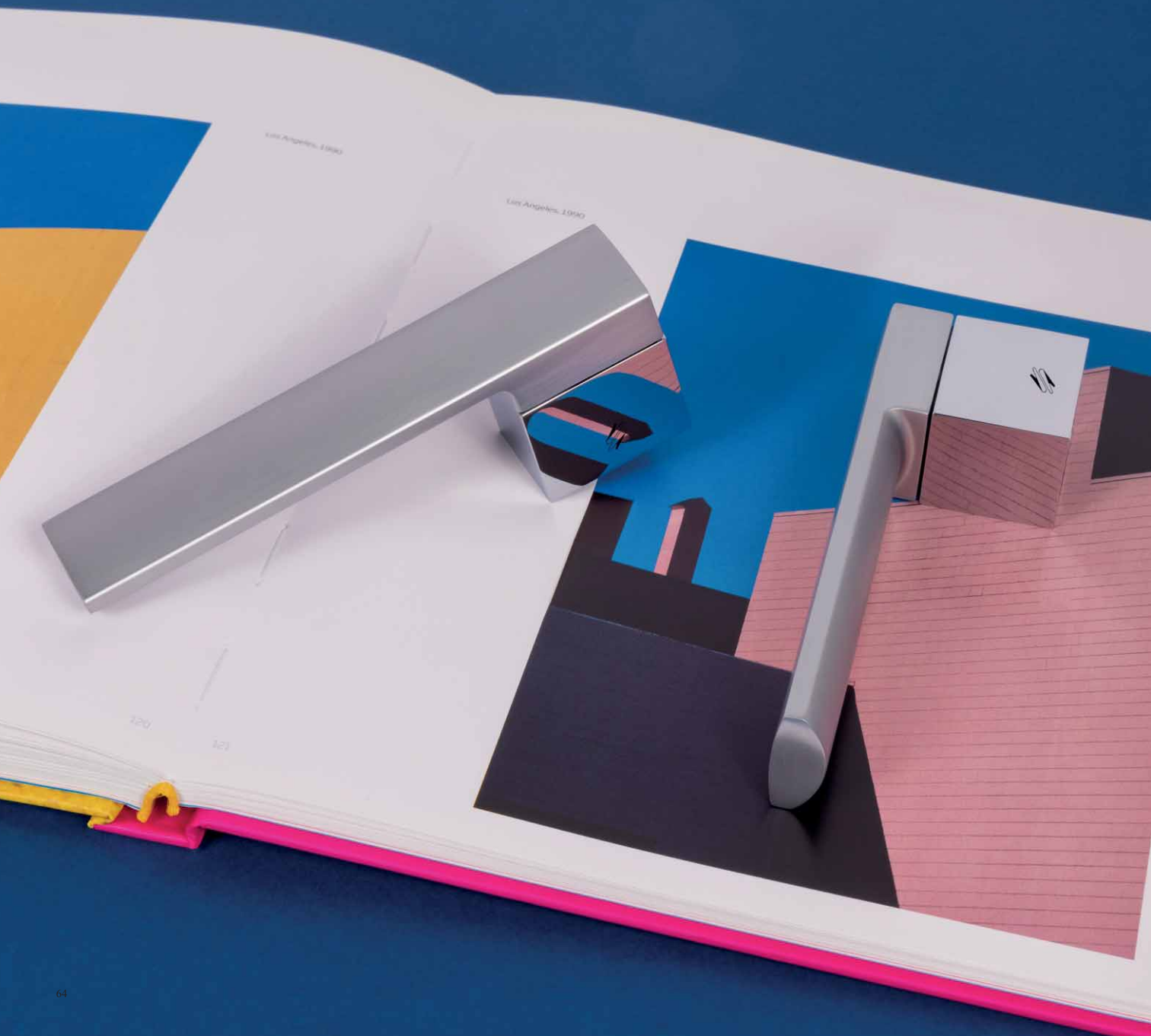

Los Angeles, 1980

Los Angeles, 1980

120

121

1963

MICK & LUKE

_963

ML 11 Design:
Mick & Luke



CM
Cromat
Matt chrome



CR/CM
Cromo/Cromat
Chrome/Matt chrome



GM
Grafite Mat
Matt graphite



GL/GM
Grafite/Grafite Mat
Graphite/Matt graphite

ML 11 RSB

ZE 29 BZG/0

LC 92 IM

LC 92 DK/SM



CR - CR/CM - GM - GL/GM

CM - GM

CR/CM - GL/GM

CR/CM - GL/GM

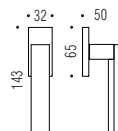
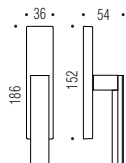
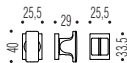
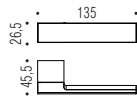



Materiale: Ottone/Cromall®
Material: Brass/Cromall®





Cadaque

PEAK

PATRICK JOUIN

PEAK

PJ 11 Design: Patrick Jouin



CR
Cromat
Chrome



CM
Cromat
Matt chrome



OM
Oromat
Matt gold



VM
Vintage Mat



GM
Grafite Mat
Matt graphite



NM RAL 9005
Neromat
Matt Black

PJ 11 R-RY Ø50

FF 19 BZG Ø50

PJ 12 IM

PJ 12 DK/SM



CR - CM - OM - VM - GM - NM

CR - CM - OM - VM - GM - NM

CR - CM - OM - VM - GM - NM

CR - CM - OM - VM - GM - NM

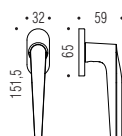
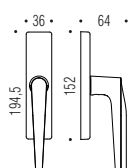
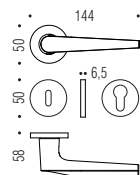



Materiale: Cromall®
Material: Cromall®





ALATÓ

STUDIO JEAN-PHILIPPE NUEL

ALATÒ

JP 11 Design:
Studio Jean-Philippe Nuel



CR
Cromo
Chrome



GL
Grafite
Graphite



CM
Cromat
Matt chrome



GM
Grafite Mat
Matt graphite

JP 11 R-RY Ø50

JP 19 BZG Ø50

JP 12 IM

JP 12 DK/SM



CR - CM - GL - GM

CR - CM - GL - GM

CR - CM - GL - GM

CR - CM - GL - GM

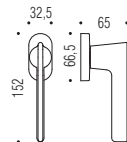
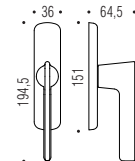
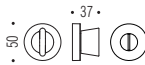
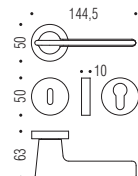



Materiale: Ottone
Material: Brass





158

ALBA

LUCA COLOMBO

ALBA

LC 91 Design:
Luca Colombo



CR/CM
Cromo/Cromat
Chrome/Matt chrome



GL/GM
Grafite/Grafite Mat
Graphite/Matt graphite



CR/NM
Cromo/Neromat
Chrome/Matt black

LC 91 R-RY 50x50

FF 29 BZG 50x50

LC 92 IM

LC 92 DK/SM



CR/CM - CR/NM - GL/GM

CR - CM - GM

CR/CM - CR/NM - GL/GM

CR/CM - CR/NM - GL/GM

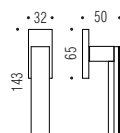
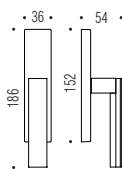
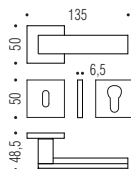



Materiale: Ottone/Cromall®
Material: Brass/Cromall®

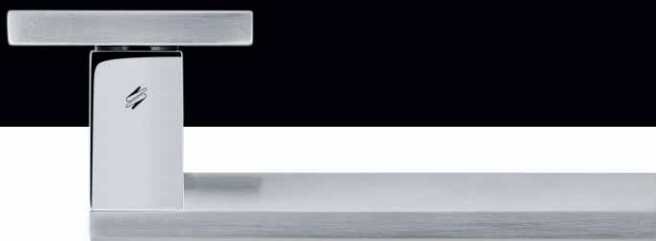



AMMA

ANDREA MAFFEI ARCHITECTS

MM

MF 11 Design:
Andrea Maffei Architects



CR
Cromo
Chrome



GL
Grafite
Graphite



CM
Cromat
Matt chrome



GM
Grafite Mat
Matt graphite

MF 11 R-RY Ø50

MF 19 BZG Ø50

MF 12 1M

MF 12 DK/SM



CR - CM - GL - GM

CR - CM - GL - GM

CR - CM - GL - GM

CR - CM - GL - GM

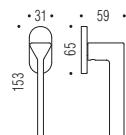
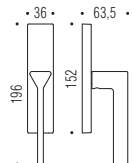
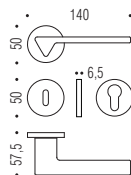



Materiale: Ottone
Material: Brass

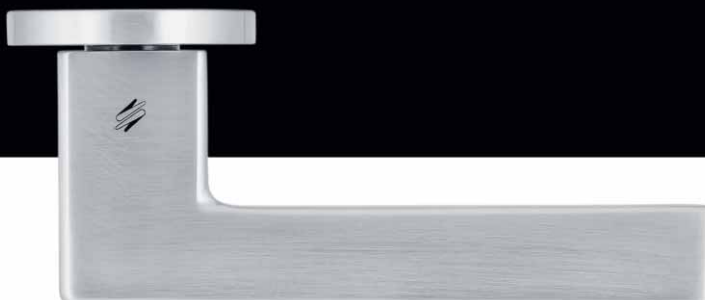



BLAZER

FRANCESCO LUCCHESI

BLAZER

FL 11 Design:
Francesco Lucchese



30
ANNI DI GARANZIA
IN TANTO TEMPO

HPS
Zirconium Gold



30
ANNI DI GARANZIA
IN TANTO TEMPO

HPS/1
Zirconium
Stainless-steel



10
ANNI DI GARANZIA
IN TANTO TEMPO

OL
Oroplus



10
ANNI DI GARANZIA
IN TANTO TEMPO

CM
Cromat
Matt chrome

FL 11 R-RY Ø50

CD 49 BZG G Ø50

FL 12 IM

FL 12 DK/SM



HPS - OL - HPS/1 - CM

HPS - OL - HPS/1 - CM

HPS - OL - HPS/1 - CM

HPS - OL - HPS/1 - CM

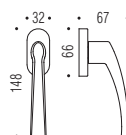
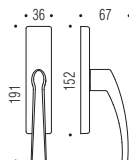
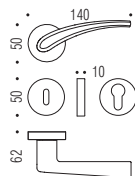



Materiale: Ottone
Material: Brass



Offset è una parola che sta a
l'immagine della bastra, l'oc
matrice cilindrica di par
do quel intrecciarsi di par
presente nell'arte contemporanea
visiva degli anni '70.

Stampero in litografia su carta da lincido

573
574
575
576
577

BOLD

PIO E TITO TOSO LAB

BOLD

PT 11 Design:
Pio e Tito Toso lab



CR
Cromo
Chrome



CM
Cromat
Matt chrome

PT 11 R-RY 52x52

PT 19 BZG 52x52

PT 12 IM

PT 12 DK/SM



CR - CM

CR - CM

CR - CM

CR - CM

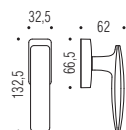
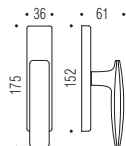
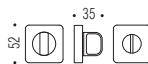
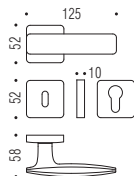



Materiale: Ottone
Material: Brass



A scuol



BOLD

PIO E TITO TOSO LAB

BOLD

PT 15 Design:
Pio e Tito Toso lab



CR
Cromo
Chrome



CM
Cromat
Matt chrome

PT 15 R-RY 52x52

PT 19 BZG 52x52



CR - CM

CR - CM

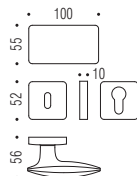



Materiale: Ottone
Material: Brass





DAYTONA

pininfarina

DAYTONA

PF 11 Design: *pininfarina*



OL
Oroplus



CM
Cromat
Matt chrome

PF 11 R-RY Ø50

CD 69 BZG G Ø50

PF 12 IM

PF 12 DK/SM



OL - CM

OL - CM

OL - CM

OL - CM

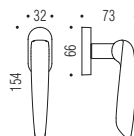
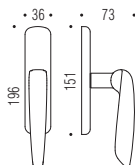
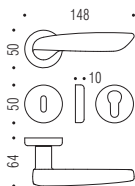



Materiale: Ottone
Material: Brass





DEA

PIO E TITO TOSO LAB

DEA

FF 21 Design:
Pio e Tito Toso lab



CR
Cromo
Chrome



CM
Cromat
Matt chrome

FF 21 R-RY 50x50



CR - CM

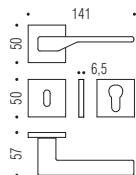

FF 29 BZG 50x50



CR - CM

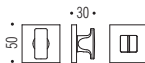

FF 22 IM



CR - CM

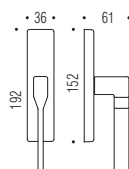

FF 22 DK/SM



CR - CM

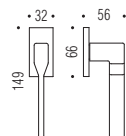

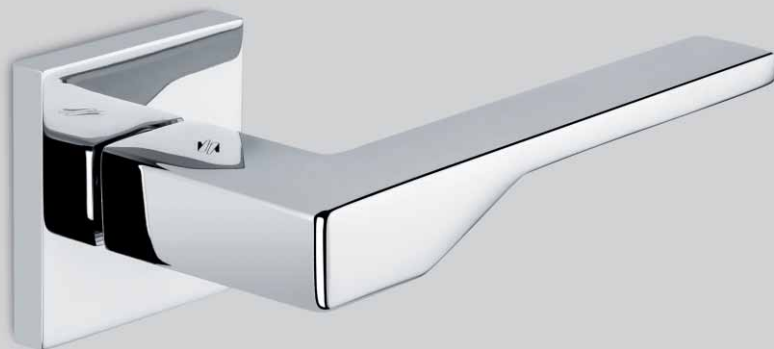

Materiale: Ottone
Material: Brass

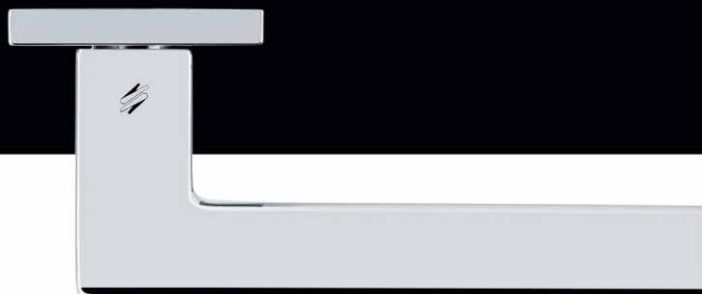

DROP

LUCA COLOMBO

DROP

LC 45 Design:
Luca Colombo



HPS
Zirconium Gold



CR
Cromo
Chrome



CM
Cromat
Matt chrome



BR
Bronzo
Bronze



NM RAL 9005
Neromat
Matt Black

LC 45 R-RY Ø50

CD 49 BZG G Ø50



HPS - CR - CM - BR - NM

HPS - CR - CM - BR - NM

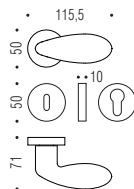

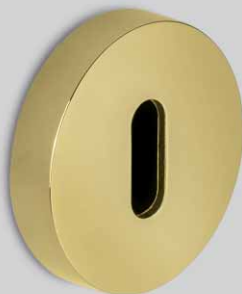
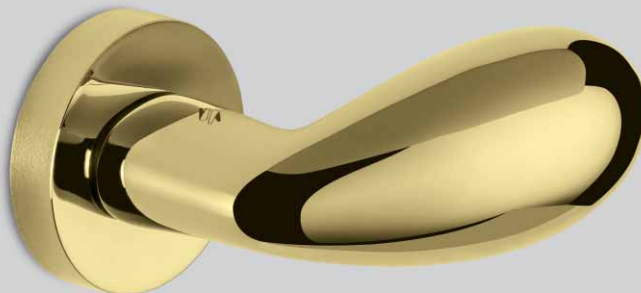

Materiale: Ottone
Material: Brass



EDO

MAKIO HASUIKE

EDO

MH 11 Design:
Makio Hasuike



OL
Oroplus



CM
Cromat
Matt chrome

MH 11 R-RY Ø50

CD 49 BZG G Ø50

MH 12 IM

MH 12 DK/SM



OL - CM

OL - CM

OL - CM

OL - CM

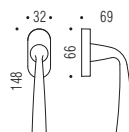
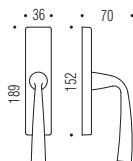
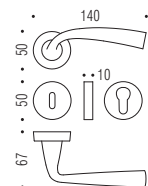



Materiale: Ottone
Material: Brass



Scultura n° 25, 1935

Scultura n° 12, 1934

ELECTRA

MESSINEO E SETTIMELLI

ELECTRA

MS 11 Design:
Messineo e Settimelli



CM
Cromat
Matt chrome



VM
Vintage Mat



NM RAL 9005
Neromat
Matt Black

MS 11 R-RY 50x50

FF 29 BZG 50x50

MS 12 IM

MS 12 DK/SM



CM - VM - NM

CM - VM - NM

CM - VM - NM

CM - VM - NM

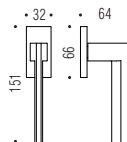
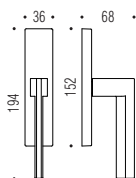
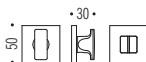
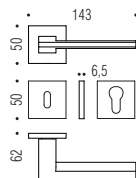

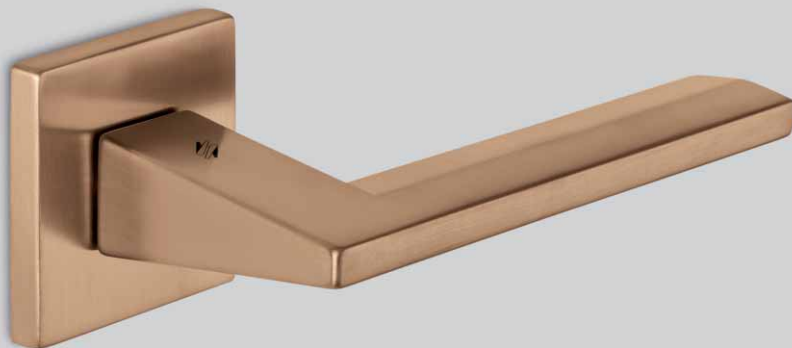

Materiale: Cromall®
Material: Cromall®

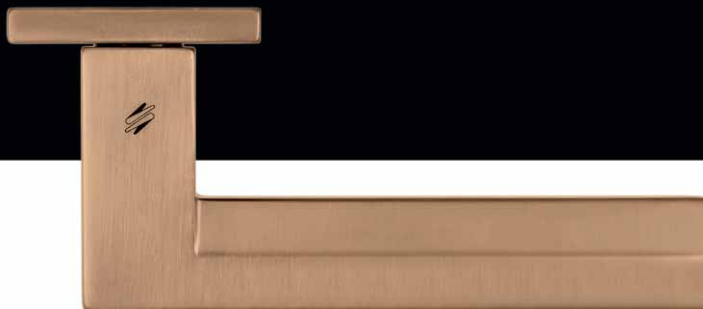

Un buon
oggetto
di design
è per
sempre.

Good
design
is
forever.

Van Day Truex



ELLE

BARTOLI DESIGN

ELLE

BD 11 Design:
Bartoli Design

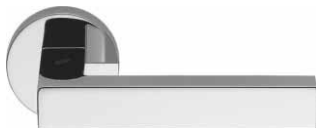

CR
Cromo
Chrome



GL
Grafite
Graphite



CM
Cromat
Matt chrome



GM
Grafite Mat
Matt graphite

BD 11 R-RY Ø50

CD 49 BZG G Ø50

BD 12 IM

BD 12 DK/SM



CR - CM - GL - GM

CR - CM - GL - GM

CR - CM - GL - GM

CR - CM - GL - GM

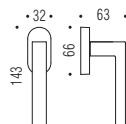
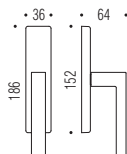
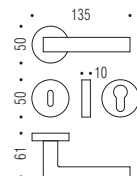



Materiale: Cromall®
Material: Cromall®



ELLE

BD 11 Design:
Bartoli Design



CR
Cromo
Chrome



CM
Cromat
Matt chrome

BD 11 RF-RYF Ø50

FF 19 BZG Ø50

BD 12 DKF/SM



CR - CM

CR - CM

CR - CM

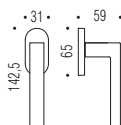
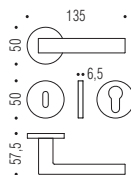

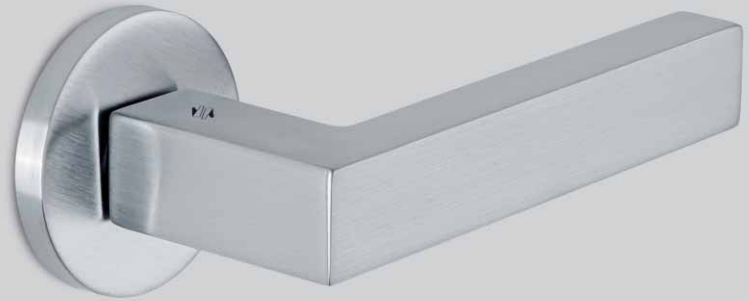

Materiale: Cromall®
Material: Cromall®



HUMAN
FIGURE



SIMBOLO DELLA PROCREAZIONE
SYMBOL OF PROCREATION

Letterio di creare la vita.

STUDIO PER AMORE E PSICHE
DI ANTONIO CANOVA

ELLESE

BARTOLI DESIGN

ELLESSE

BD 21 Design:
Bartoli Design



CR
Cromo
Chrome



GL
Grafite
Graphite



CM
Cromat
Matt chrome



GM
Grafite Mat
Matt graphite

BD 21 R-RY 52x52



CR - CM - GL - GM

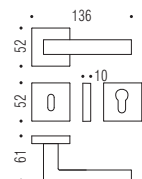

MM 29 BZG 52x52



CR - CM - GL - GM

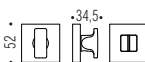

BD 12 IM



CR - CM - GL - GM

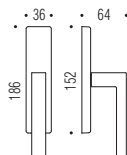

BD 22 DK/SM



CR - CM - GL - GM

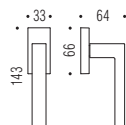



Materiale: Cromall®
Material: Cromall®

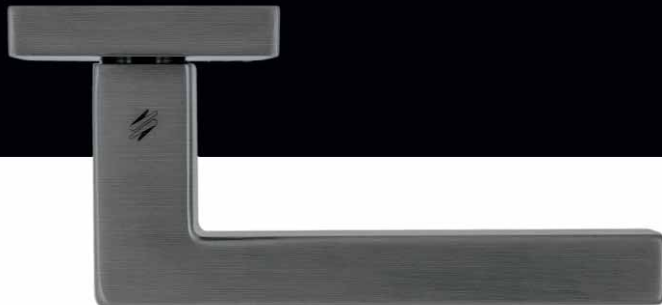

ELLESSE

BD 21 Design:
Bartoli Design



CR
Cromo
Chrome

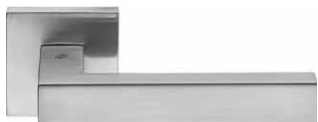

CM
Cromat
Matt chrome

BD 21 RF-RYF 50x50

FF 29 BZG 50x50

BD 22 DKF/SM



CR - CM

CR - CM

CR - CM

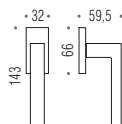
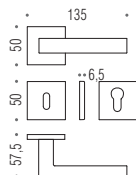



Materiale: Cromall®
Material: Cromall®



FINITURA GARANTITA 10 ANNI
FINISHING 10 YEARS WARRANTY

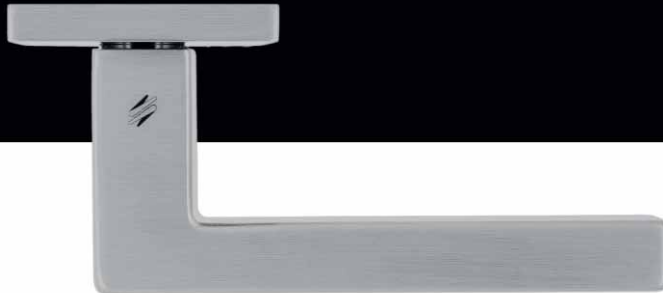

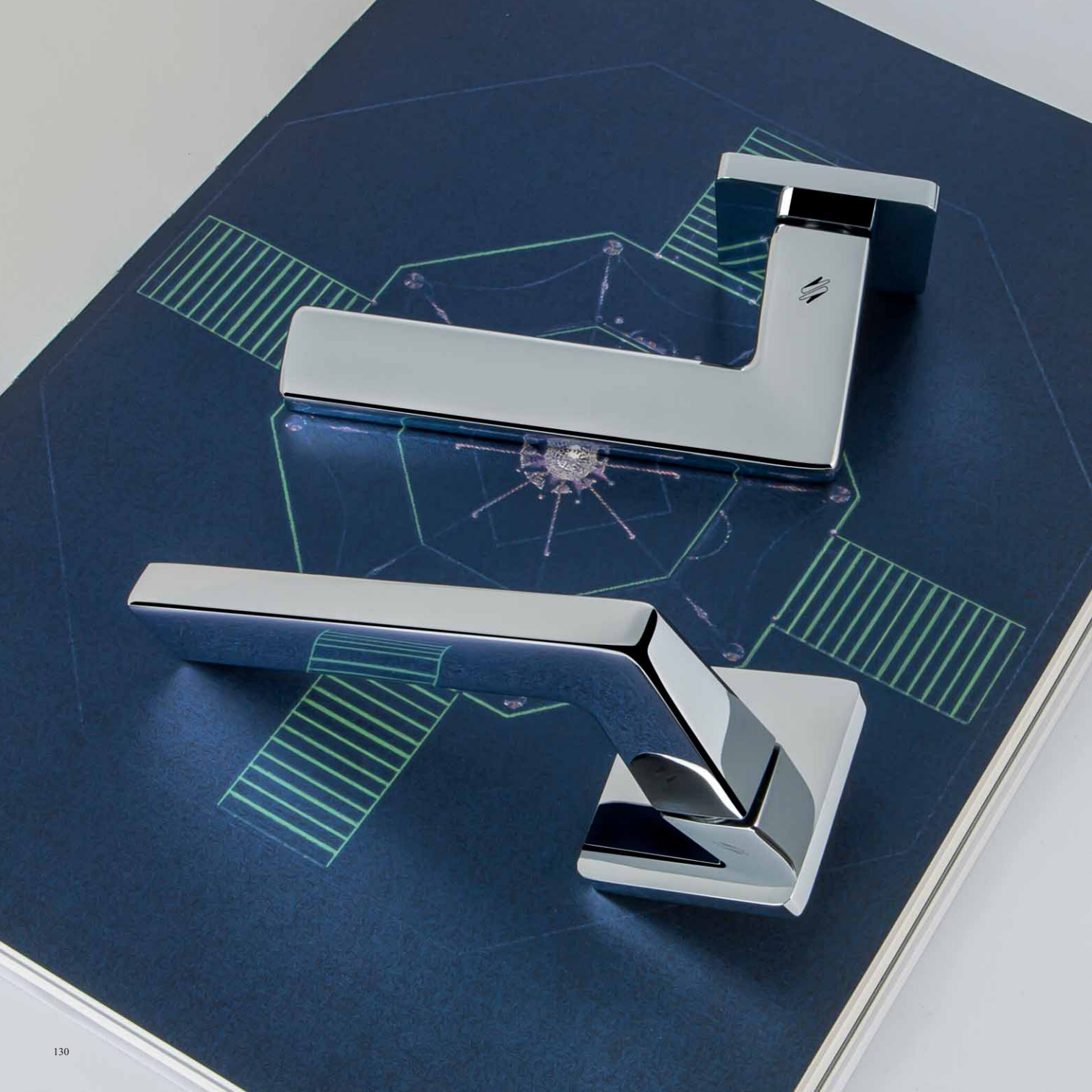

ESPRIT

BIRGIT LOHMANN

ESPRIT

BT 11 Design:
Birgit Lohmann



CR
Cromo
Chrome



HPS/1
Zirconium
Stainless-steel



CM
Cromat
Matt chrome

BT 11 R-RY 50x50



HPS/1 - CR - CM

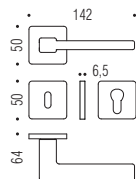

BT 19 BZG 50x50



HPS/1 - CR - CM



BT 12 IM



HPS/1 - CR - CM

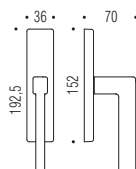

BT 12 DK/SM



HPS/1 - CR - CM

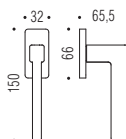



Materiale: Ottone
Material: Brass



Due alberi per



Un albero
al centro della stanza
deserta.
Senza soffitto.
Accanto al grande albero
forse
l'uomo ricorda.
Adesso
la voce di un solo bimbo.
L'albero è un giorno
non finito.
Anche le palline di vetro
sfumavano
tra le dita del bimbo.
Era una risata

89

89
raggi.

FEDRA

ANDREA CASTRIGNANO

FEDRA

AC 11 Design:
Andrea Castrignano

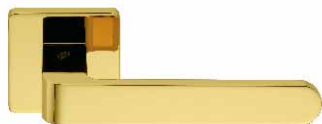

OL
Oroplus

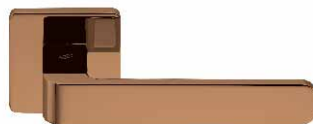

VL
Vintage

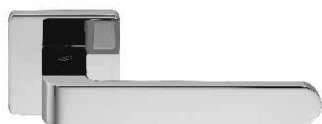

CR
Cromo
Chrome



VM
Vintage Mat

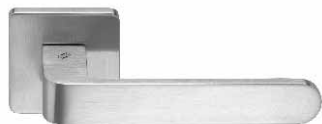

CM
Cromat
Matt chrome



NM RAL 9005
Neromat
Matt Black

AC 11 R-RY 50x50

BT 19 BZG 50x50

AC 12 IM

AC 12 DK/SM



OL - CR - CM - VL - VM - NM

OL - CR - CM - VL - VM - NM

OL - CR - CM - VL - VM - NM

OL - CR - CM - VL - VM - NM

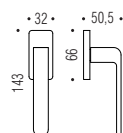
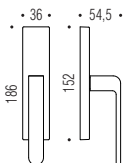
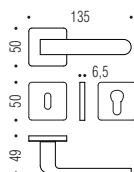



Materiale: Ottone
Material: Brass





FLESSA

CARLO BARTOLI

FLESSA

CB 51 Design:
Carlo Bartoli



HPS
Zirconium Gold



CM
Cromat
Matt chrome



OL
Oroplus



NI
Nikelmat
Matt nickel

CB 51 R-RY Ø50

CD 49 BZG G Ø50

CB 52 M

CB 52 DK/SM DX-SX



HPS - OL - CM - NI

HPS - OL - CM - NI

HPS - OL - CM - NI

HPS - OL - CM - NI

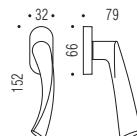
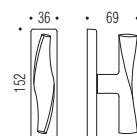
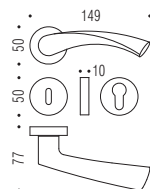



Materiale: Ottone
Material: Brass





GAIA

GIULIO RIPAMONTI

GAIA

GR 11 Design:
Giulio Ripamonti



OL
Oroplus



CM
Cromat
Matt chrome



CR
Cromo
Chrome

GR 11 R-RY Ø50

CD 49 BZG G Ø50

GR 12 IM

GR 12 DK/SM



OL - CR - CM

OL - CR - CM

OL - CR - CM

OL - CR - CM

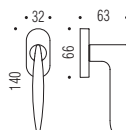
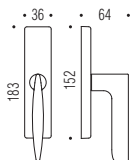
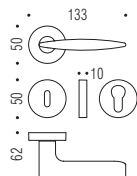



Materiale: Ottone
Material: Brass



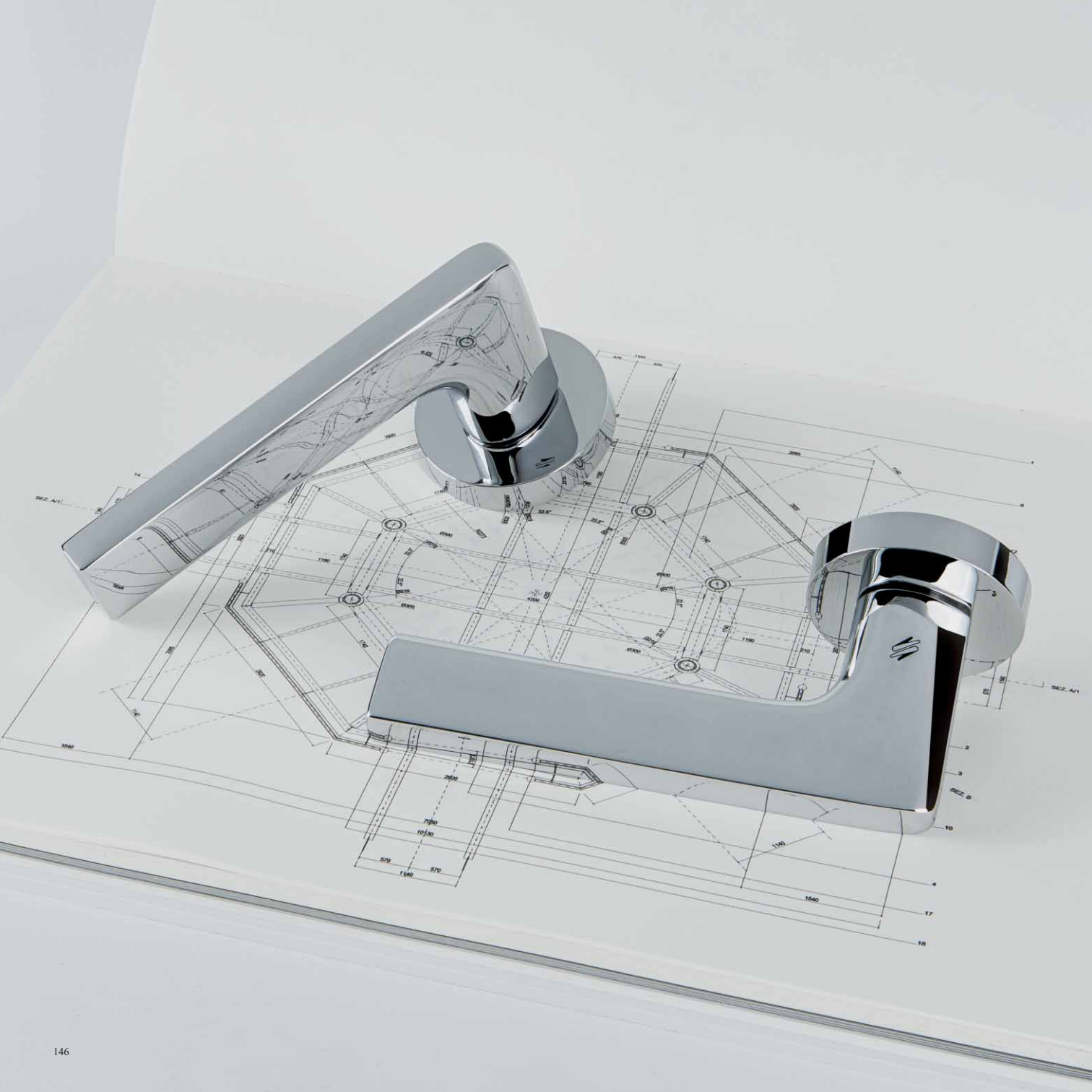

GIRA

JASPER MORRISON

GIRA

JM 11 Design:
Jasper Morrison



OL
Oroplus



HPS/1
Zirconium
Stainless-steel



CR
Cromo
Chrome



VL
Vintage



CM
Cromat
Matt chrome



VM
Vintage Mat

JM 11 R-RY Ø50

CD 49 BZG G Ø50

JM 12 IM

JM 12 DK/SM



OL-HPS/1-CR-CM-VL-VM

OL-HPS/1-CR-CM-VL-VM

OL-CR-CM-VL-VM

OL-HPS/1-CR-CM-VL-VM

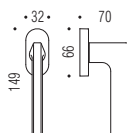
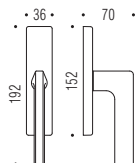
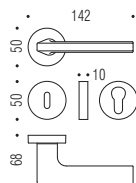



Materiale: Ottone
Material: Brass





194

LUTA BETTONICA E GIANCARLO LEONE

ISY

BL 11 Design:
Luta Bettonica e Giancarlo Leone



CR
Cromo
Chrome



CM
Cromat
Matt chrome

BL 11 R-RY 52x52

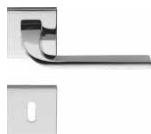

CR - CM

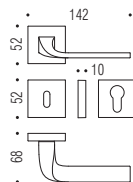

MM 29 BZG 52x52



CR - CM

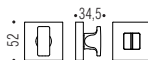

BL 12 IM



CR - CM

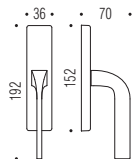

BL 12 DK/SM



CR - CM

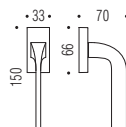



Materiale: Ottone
Material: Brass

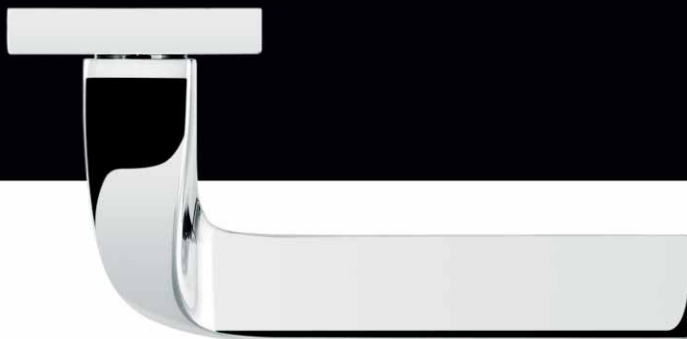

ISY

BL 11 Design:
Luta Bettonica e Giancarlo Leone



CR
Cromo
Chrome



CM
Cromat
Matt chrome

BL 11 RF-RYF 50x50

FF 29 BZG 50x50

BL 12 DKF/SM



CR - CM

CR - CM

CR - CM

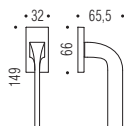
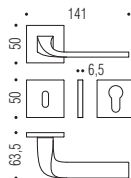

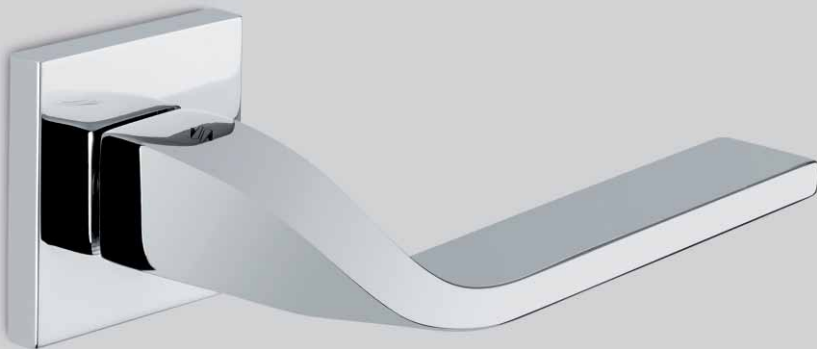

Materiale: Ottone
Material: Brass





LARA

CARLO BARTOLI

LARA

CB 71 Design:
Carlo Bartoli



HPS
Zirconium Gold



CM
Cromat
Matt chrome



OL
Oroplus



NI
Nikelmat
Matt nickel



OM
Oromat
Matt gold

CB 71 R-RY Ø50

CD 49 BZG G Ø50

CB 72 IM

CB 72 DK/SM



HPS - OL - OM - CM - NI

HPS - OL - OM - CM - NI

HPS - OL - OM - CM - NI

HPS - OL - OM - CM - NI

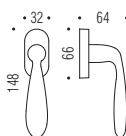
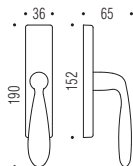
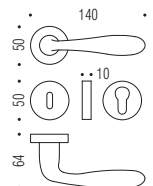



Materiale: Ottone
Material: Brass



L'agricoltura è la ragione di uno degli utilizzi più avidi del nostro liquido più prezioso. Al giorno d'oggi, per esempio più dell'ottanta per cento del consumo d'acqua negli Stati Uniti è impiegato all'agricoltura. La scelta di convertire terre scongelate ma aride in zone di coltivazione intensa ha inevitabilmente provocato un conseguente e dalle piogge. La situazione in California è particolarmente grave per la siccità che non di segni di esaurimento e per la lunga storia di approvvigionamento esotismo e scriterio nei decenni passati. L'Imperial Valley, vasta regione agricola attraversata dall'All-American Canal, seguita ad attingere da questo canale artificiale per un tragico errore di distribuzione e delinea cerchi magici sul terreno. E' il bacino di Borinsky è andato a fotografare anche un altro tipo d'innaffiamento molto fotografico per gli incredibili disegni che si creano nel paesaggio e particolarmente utilizzato in Texas. E' l'irrigazione a pivot centrale, che riduce lo spreco d'acqua per la sua estrema precisione e in modo estremamente artistico. E' un tipo di coltivazione praticata in poche zone, nella regione di Los Monegros (Argentina) luogo in cui la biochimica per legge.

IRRIGAZIONE A PIVOT N. 7
HIGH PLAINS, PANHANDLE, TEXAS, USA



LIBRA

STUDIO KAIROS

LIBRA

SK 21 Design:
Studio Kairos



OL
Oroplus



CR
Cromo
Chrome

SK 21 R-RY Ø50

CD 49 BZG G Ø50

SK 22 M

SK 22 DK/SM



OL - CR

OL - CR

OL - CR

OL - CR

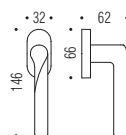
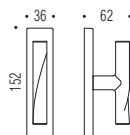
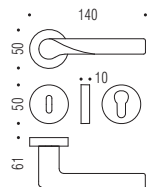



Materiale: Ottone
Material: Brass



sensazioni un...
dinanzi ai miei quadri c'è
in grado di dare espressione compie la sua
che dinanzi ai miei dipinti piange voi, come avete l'essenziale
compio quando li dipingo. E allora vi sfugge l'essenziale
dei loro rapporti cromatici, allora vi sfugge il monodimensionalità
Per paura di essere catalogato in modo monodimensionale
rifiutava di aggiungere che lo interessava il medium
che il colore fosse per lui un mezzo espressivo, «cosa
c'è più una linea», disse a Elaine De Kooning,
potrebbe ancora dipingere?». I mezzi di rappresentazione
soprattutto un sistema per comunicare le campiture
solamente un sistema cromatiche, quindi le campiture
Per lui, le estensioni cromatiche, quindi le campiture
che si trasmetteva all'osservatore. A partire dal 1958
Rothko fu sempre più portato a utilizzare una gamma
impiegava meno toni rossi, gialli e arancioni, più
come marrone, grigio, blu scuro e nero. Nel 1958
nella Sidney Janis Gallery (ottobre 1958), i dipinti
accessibili, più scuri e misteriosi.



LUND

CLAESSON KOIVISTO RUNE

LUND

SE 11 Design:
Claesson Koivisto Rune



CR
Cromo
Chrome



GL
Grafite
Graphite



CM
Cromat
Matt chrome



GM
Grafite Mat
Matt graphite

SE 11 R-RY Ø50

SE 19 BZG Ø50

SE 12 IM

SE 12 DK/SM



CR - CM - GL - GM

CR - CM - GL - GM

CR - CM - GL - GM

CR - CM - GL - GM

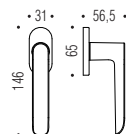
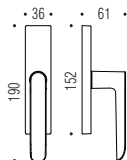
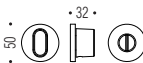
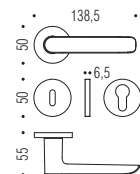



Materiale: Ottone
Material: Brass



Il design
è il nucleo
centrale
di una
creazione
umana.

Design
is the
fundamental
soul of a
human-made
creation.

Steve Jobs

Map of

- 01 Edilizia Residenziale
- 02 Edilizia Residenziale
- 03 Centrale Termica per l'Istruzione / Treno Laminatoio / Città della Salute e Centro Polivalente / T3 Pagoda / Piazza Cop
- 04 Stazione a scavalco OMEC / Mercato
- 05 Cabina Controllo coperto
- 06 Plesso scolastico Carri Merc
- 07 Scuola dell'infanzia Concordia
- 08 Edilizia Residenziale Ex Montessa
- 09 BLISS / Biblioteca
- 10 Rettifica filiere / R.S.A.
- 11 Pollambulatorio
- 12 Asilo nido
- 13 Edilizia Residenziale Sociale
- 14 Edilizia Residenziale Sociale
- 15 Edilizia Residenziale Sociale
- 16 Edilizia Residenziale Sociale
- 17 Edilizia Residenziale Sociale
- 18 Edilizia Residenziale Sociale
- 19 Edilizia Residenziale Sociale

Legenda
Legend



MADI

ALBERTO MEDA

MADI

AM 31 Design:
Alberto Meda

A
Selezione d'onore
Compasso d'Oro
ADI 1998



OL
Oroplus



CM
Cromat
Matt chrome



OM
Oromat
Matt gold

AM 31 R-RY Ø50

CD 49 BZG G Ø50

AM 32 M

AM 32 DK/SM DX-SX



OL - OM - CM

OL - OM - CM

OL - OM - CM

OL - OM - CM

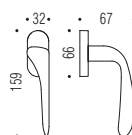
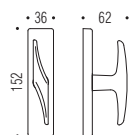
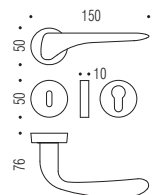

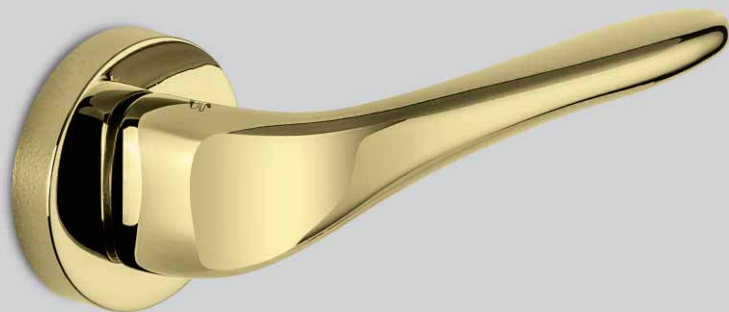

Materiale: Ottone
Material: Brass



Le tracce del Maestro The Traces of the Master

Kinue Horikawa

Gli schizzi di Angelo Mangiarotti sorprende: all'origine di ogni progetto di design o un'opera di scultura – traccia precoce delle sue prime intuizioni a qualunque genere di realizzazione perfettamente congruenti con le volte ancora più che le fotografie dei schizzi a rivelare fedelmente l'afflato con il quale ha ispirato l'idea stessa dell'opera. Fatalmente, nel corso della sua realizzazione, subire una serie di modifiche attribuite a committenza, a motivi economici o a gettazione stessa. Com'è ovvio, non a questa norma molte opere di Angelo Mangiarotti subirono subito anche modifiche in fase di sviluppo, malgrado tutto, la stretta vicinanza tra le prime intuizioni abbozzate negli schizzi e le realizzazioni finali non può non essere ascritto all'eccezionale coerenza, in ogni situazione, Mangiarotti prevedendo chiaramente un profilo di sviluppo per non snaturare il progetto originario. Gli schizzi dei progetti architettonici e i disegni, ma rivelano altresì un'attenzione particolare per le modalità di costruzione della fabbrica. In ogni occasione, a ogni fase, dedicava la propria attenzione in maniera concreta con la maggiore esattezza possibile in mente per realizzarlo compiutamente. Una linea curva, tracciata con apparente noncuranza, per gli schizzi degli oggetti di design e della realtà tecnicamente possibile la loro realizzazione all'atto pratico eseguita con tutta la cura e la potenzialità dei materiali adoperati. Si tratta di una logica che si giustifica anche in termini di comprensione come egli abbozzasse i progetti e calcolando all'istante, in modo tale da poter realizzare un'opera un'identità unica. Per Angelo Mangiarotti gli schizzi erano o



M A P O

MAURO RONCHI

MAPO

RM 15 Design:
Mauro Ronchi



CR
Cromo
Chrome



NM RAL 9005
Neromat
Matt Black



CM
Cromat
Matt chrome

RM 15 R-RY Ø50

CD 49 BZG G Ø50



CR - CM - NM

CR - CM - NM

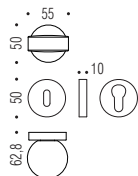



Materiale: Ottone
Material: Brass





META

KONSTANTIN GRČIĆ

META

KG 11 Design:
Konstantin Grcic



CR
Cromo
Chrome



CM
Cromat
Matt chrome

KG 11 R-RY Ø50



CR - CM

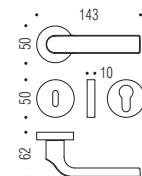

CD 49 BZG G Ø50



CR - CM



KG 12 IM



CR - CM

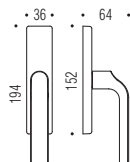

KG 12 DK/SM



CR - CM

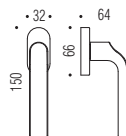



Materiale: Ottone
Material: Brass





MILLA

LUCA COLOMBO

MILLA

LC 31 Design:
Luca Colombo



OL/OM
Oroplus/Oromat
Oroplus/Matt gold



CR/CM
Cromo/Cromat
Chrome/Matt chrome

LC 31 R-RY Ø50

CD 49 BZG G Ø50

LC 32 IM

LC 32 DK/SM



OL/OM - CR/CM

OM - CM

OL/OM - CR/CM

OL/OM - CR/CM

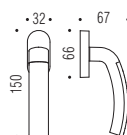
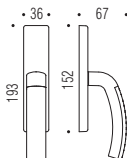
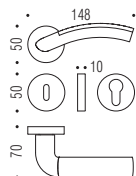



Materiale: Cromall®
Material: Cromall®





15 km di circuiti
ciclopeditoni
15 kilometers
of bicycle and
pedestrian circuits

Prospettive panoramiche
da Milanosesto.
Panoramic view
from Milanosesto.

MILLA

LUCA COLOMBO

MILLA

LC 41 Design:
Luca Colombo



OL/OM
Oroplus/Oromat
Oroplus/Matt gold



CR/CM
Cromo/Cromat
Chrome/Matt chrome

LC 41 R-RY Ø50

CD 49 BZG G Ø50

LC 42 IM

LC 42 DK/SM



OL/OM - CR/CM

OM - CM

OL/OM - CR/CM

OL/OM - CR/CM

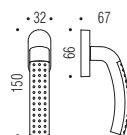
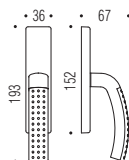
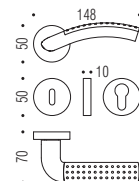

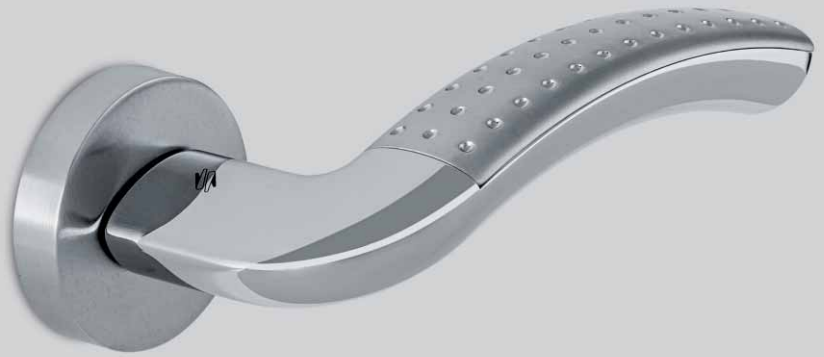

Materiale: Cromall®
Material: Cromall®

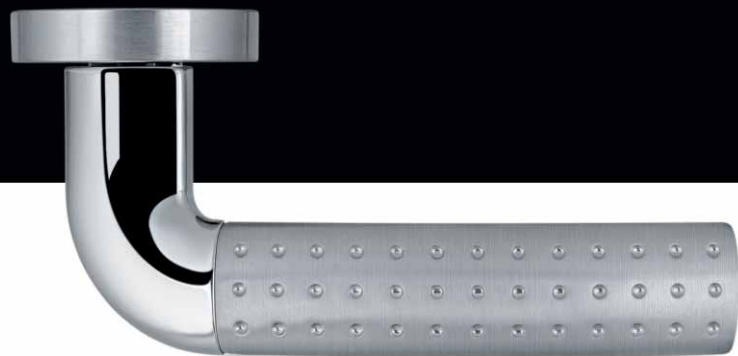

DOMINICO MIRIAMMO



Ma non è solo questo. Nel trionfo del registro
comico, l'umorismo ambrosiano - paradosale e
stanzato - risulta sfavante: e meno immediato di
quello napoletano o romano, il suo stesso dialetto
- all'epoca poco considerato dagli stessi milanesi
- è meno comprensibile all'uditorio nazionale
e internazionale. Sarà per questo che le commedie
di maggior successo nazionale raccontano di
inverosimili a Milano napoletani come Eduardo
de Filippo e Steno tutti
trasformazione dal "boom" delle bombe al boom
del "cane" e dalle macerie ai grattacieli. Il 1953
è l'anno dell'arrivo dei migranti in Napoli
a Milano di Eduardo De Filippo e Steno tutti
milanesi di Mario Landi.



...cominciò a
cineasta gra...
la leggerezza nar...
scritto, e dal reor...
quotidianità della me...
ha meglio interpretat...
grazie alla possibiltà d...
la scelta dell'ironia. Mil...
...metri...
...catt...
...quasi es...
...in genere...
...anche...
...mente...
...stra...
...ra

MIXA

CARLO BARTOLI

MIXA

CB 21 Design:
Carlo Bartoli



OL/OM
Oroplus/Oromat
Oroplus/Matt gold



CR/CM
Cromo/Cromat
Chrome/Matt chrome

CB 21 R-RY Ø50

CD 49 BZG G Ø50

CB 22 M

CB 22 DK/SM DX-SX



OL/OM - CR/CM

OL - CM

OL/OM - CR/CM

OL/OM - CR/CM

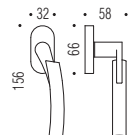
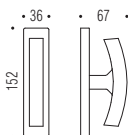
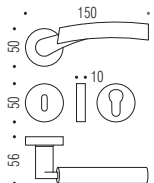



Materiale: Ottone
Material: Brass



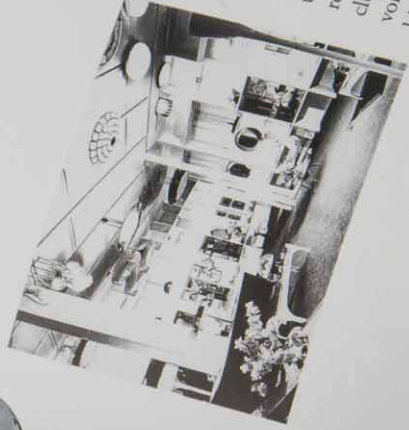

...zeal
...his own
...excuber
...with
...could not
...beautiful
...Ponti ins
...borne his
...understan
...w

MOON

BARTOLI DESIGN

MOON

BD 15 Design:
Bartoli Design



HPS
Zirconium Gold



CM
Cromat
Matt chrome



CR
Cromo
Chrome

BD 15 R-RY Ø50

CD 49 BZG G Ø50



HPS - CR - CM

HPS - CR - CM

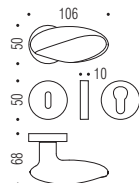



Materiale: Ottone
Material: Brass





OLLY

LUCA COLOMBO

OLLY

LC 61 Design:
Luca Colombo



OL
Oroplus



CM
Cromat
Matt chrome



CR
Cromo
Chrome

LC 61 R-RY Ø50

CD 49 BZG G Ø50

LC 62 IM

LC 62 DK/SM



OL - CR - CM

OL - CR - CM

OL - CR - CM

OL - CR - CM

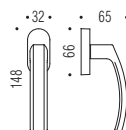
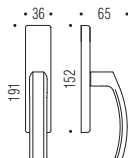
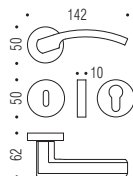

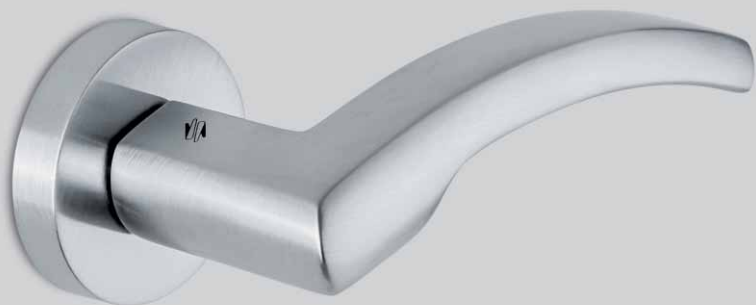

Materiale: Ottone
Material: Brass





ed progetto
per il project

100.000 mq/sm

8

Nuovi alberi
New trees

10.000

PROGETTO E CARATTERIZZATO
GRUPPO SLIP
D
ZATO
ATE
characterized
designated

PEGASO

ALBERTO MEDA

PEGASO

AM 11 Design:
Alberto Meda



CR
Cromo
Chrome



CM
Cromat
Matt chrome

AM 11 R-RY Ø50

CD 49 BZG G Ø50

AM 12 M

AM 12 DK/SM



CR - CM

CR - CM

CR - CM

CR - CM

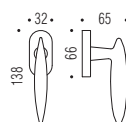
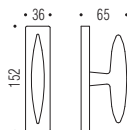
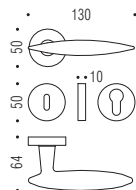

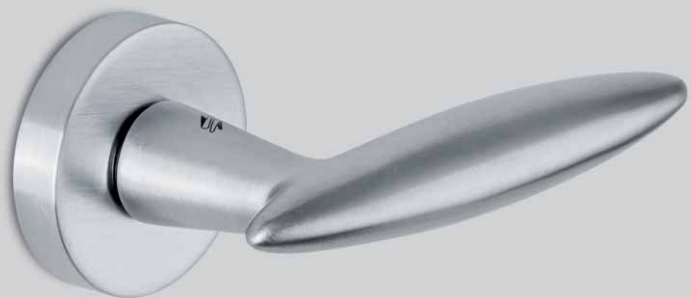

Materiale: Ottone
Material: Brass



子神聖性
光見可る



PRIUS

MARCO ACERBIS

PRIUS

MA 11 Design:
Marco Acerbis

A
Selezione d'onore
Compasso d'Oro
ADI 2008



CR
Cromo
Chrome



CM
Cromat
Matt chrome

MA 11 R-RY 52x52



CR - CM

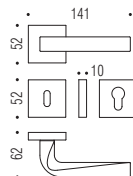

MM 29 BZG 52x52



CR - CM

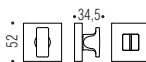

MA 12 IM



CR - CM

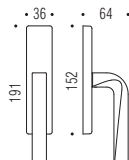

MA 12 DK/SM



CR - CM

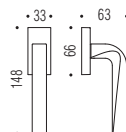



Materiale: Ottone
Material: Brass



strada a secco,
e
scalo piano.



SIRIO

COLOMBO DESIGN

SIRIO

CD 11 Design:
Colombo Design



OL
Oroplus



CR
Cromo
Chrome



CM
Cromat
Matt chrome

CD 11 R-RY Ø50

CD 69 BZG G Ø50

CD 12 M

CD 12 DK/SM DX-SX



OL - CR - CM

OL - CR - CM

OL - CR - CM

OL - CR - CM

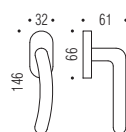
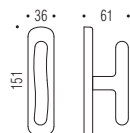
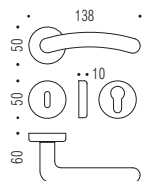

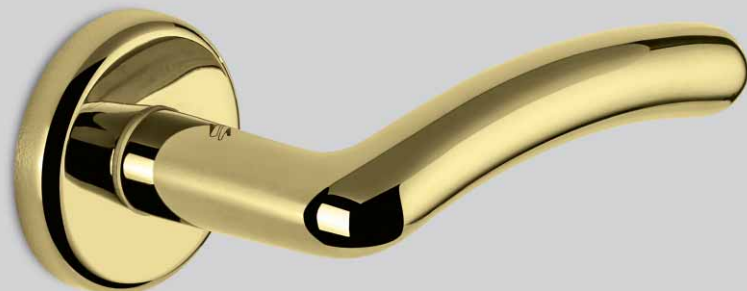

Materiale: Ottone
Material: Brass



Se ritieni che
un buon design
sia costoso,
dovresti
considerare
il costo di un
cattivo design.

If you
think that
good design
is expensive,
you should
look at the cost
of bad design.

Ralf Speth

174 I DIPINTI DI VAN GOGH



SLIM

STUDIO SPALVIERI / DEL CIOTTO

SLIM

FF 11 Design:
Studio Spalvieri / Del Ciotto



CR
Cromo
Chrome



CM
Cromat
Matt chrome

FF 11 R-RY Ø50

FF 19 BZG Ø50

FF 12 IM

FF 12 DK/SM



CR - CM

CR - CM

CR - CM

CR - CM

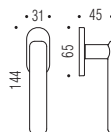
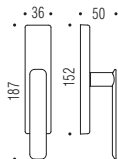
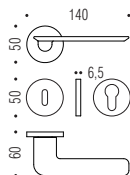



Materiale: Ottone
Material: Brass





SPIDER

MATTEO RAGNI

SPIDER

MR 11 Design:
Matteo Ragni



CR
Cromo
Chrome



CM
Cromat
Matt chrome

MR 11 R-RY 51x51



CR - CM

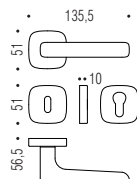

MR 29 BZG G 51x51



CR - CM

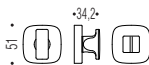

MR 12 IM



CR - CM

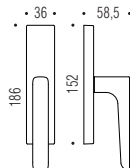

MR 12 DK/SM



CR - CM

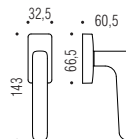



Materiale: Ottone
Material: Brass





SPIDER

MATTEO RAGNI

SPIDER

MR 15 Design:
Matteo Ragni



CR
Cromo
Chrome



CM
Cromat
Matt chrome

MR 15 R-RY 51x51

MR 29 BZG G 51x51



CR - CM

CR - CM

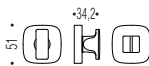
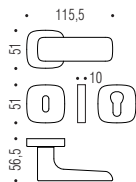



Materiale: Ottone
Material: Brass





STAR

COLOMBO DESIGN

STAR

CD 01 Design:
Colombo Design



CM
Cromat
Matt chrome



NM RAL 9005
Neromat
Matt Black

CD 01 R-RY Ø50

CD 69 BZG G Ø50

CD 02 IM

CD 02 DK/SM



CM - NM

CM - NM

CM - NM

CM - NM

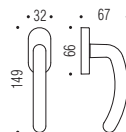
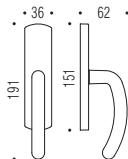
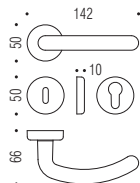



Materiale: Ottone
Material: Brass





TACTA

CARLO BARTOLI

TACTA

CB 11 Design:
Carlo Bartoli



NI/PE
Nikelmat/Pero
Matt nickel/Pear wood



NI/EM
Nikelmat/Ebano makassar
Matt nickel/Makassar ebony

CB 11 R-RY Ø48

CD 39 BZG Ø48

CB 12 IM



NI/PE - NI/EM

NI

NI/PE - NI/EM

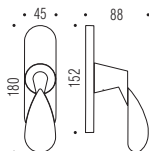

Le differenze di venatura e colore che si riscontrano sul particolare in legno, sono dovute esclusivamente all'utilizzo di masselli
Grain and colour differences you notice on the piece are natural characteristics of the genuine wood

Materiale: Ottone e Legno massello
Material: Brass and genuine wood





TALLA

LUCA COLOMBO

TAILLA

LC 51 Design:
Luca Colombo



OL/OM
Oroplus/Oromat
Oroplus/Matt gold



CR/CM
Cromo/Cromat
Chrome/Matt chrome

LC 51 R-RY Ø50

CD 49 BZG G Ø50

LC 52 IM

LC 52 DK/SM



OL/OM - CR/CM

OL - CR

OL/OM - CR/CM

OL/OM - CR/CM

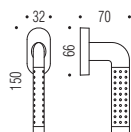
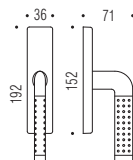
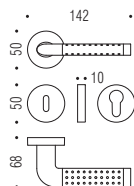

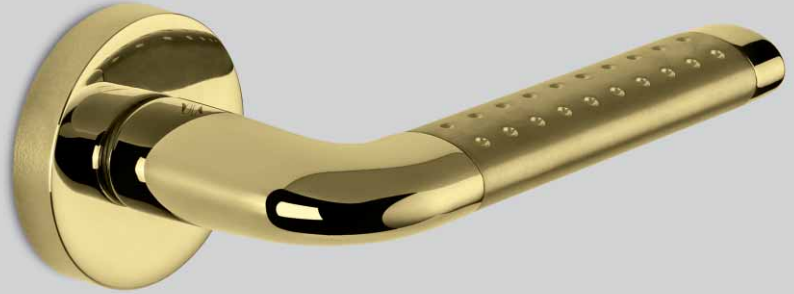

Materiale: Cromall®
Material: Cromall®

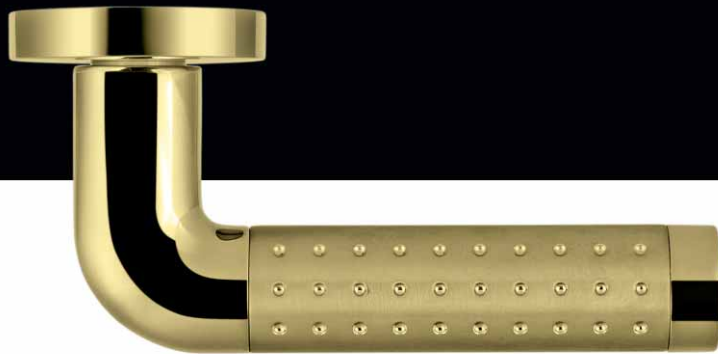



they remain high
that icy lea

TAIPAN

LUCA COLOMBO

TAIPAN

LC 11 Design:
Luca Colombo



OL/OM
Oroplus/Oromat
Oroplus/Matt gold



CR/CM
Cromo/Cromat
Chrome/Matt chrome

LC 11 R-RY Ø50

CD 49 BZG G Ø50

LC 12 IM

LC 12 DK/SM



OL/OM - CR/CM

OL - CR

OL/OM - CR/CM

OL/OM - CR/CM

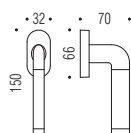
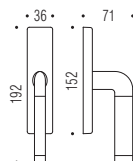
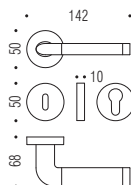



Materiale: Cromall®
Material: Cromall®





TALITA

LUCA COLOMBO

TALITA

LC 21 Design:
Luca Colombo



OL/OM
Oroplus/Oromat
Oroplus/Matt gold



CM/CR
Cromat/Cromo
Matt chrome/Chrome

LC 21 R-RY Ø50

CD 69 BZG G Ø50

LC 22 IM

LC 22 DK/SM



OL/OM - CM/CR

OL - CM

OL/OM - CM/CR

OL/OM - CM/CR

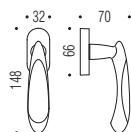
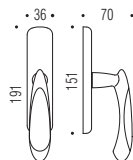
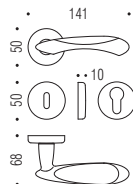



Materiale: Cromall®
Material: Cromall®





TECNO

momaDESIGN

TECNO

MO 11 Design: **mamaDESIGN**



CM/CR
Cromat/Cromo
 Matt chrome/Chrome

MO 11 R-RY 50x50



CM/CR

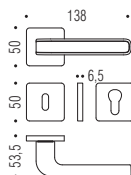

BT 19 BZG 50x50



CM



MO 12 IM



CM/CR

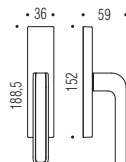

MO 12 DK/SM



CM/CR

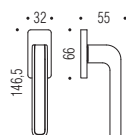



Materiale: Cromall®
Material: Cromall®



...di vento da 175°
...a malissima,
...tra puntate sulla
...Luna Rossa,
...se reggite
...dimenticata
...di "l'ideale"
...no più
...greci
...attesa
...anche
...Ange

Die dei lati con il vento in poppa più
entusiasmi della Louis Vuitton cup
va e ricostruito l'ultimo tratto del terzo
era regata di finale il 30 gennaio 2000.
mod di vento da 260° a circa
quardo Capard va a mettersi
Nuvola srambata
200 metri del traguardo.
Siva De Angelis
re verso
tecnici:
Grael.



Incor

TENDER

ARCHITETTURA LABORATORIO

TENDER

MG 11 Design:
Architettura Laboratorio



OL
Oroplus



CM
Cromat
Matt chrome



NI
Nikelmat
Matt nickel

MG 11 R-RY Ø50

CD 49 BZG G Ø50

MG 12 IM

MG 12 DK/SM



OL - CM - NI

OL - CM - NI

OL - CM - NI

OL - CM - NI

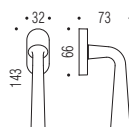
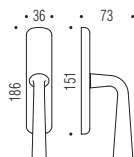
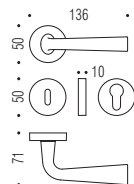



Materiale: Ottone
Material: Brass





TOOL

MICHELE DE LUCCHI

TOOL

MD 11 Design:
Michele De Lucchi



CR
Cromo
Chrome



CM
Cromat
Matt chrome

MD 11 R-RY Ø50

CD 49 BZG G Ø50

MD 12 IM

MD 12 DK/SM



CR - CM

CR - CM

CR - CM

CR - CM

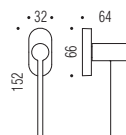
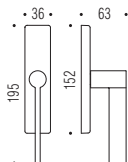
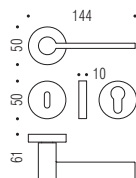



Materiale: Ottone
Material: Brass



TOOL

MD 11 Design:
Michele De Lucchi



CR
Cromo
Chrome



CM
Cromat
Matt chrome

MD 11 **RF-RYF** Ø50

FF 19 **BZG** Ø50

MD 12 **DKF/SM**



CR - CM

CR - CM

CR - CM

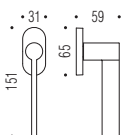
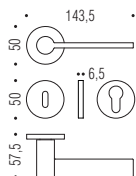



Materiale: Ottone
Material: Brass

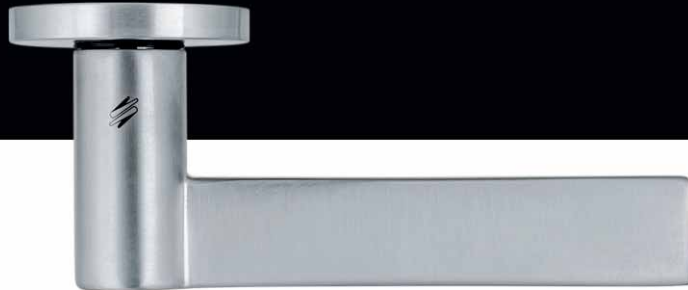

I dettagli
non sono
dettagli.
Fanno
il design.

The details
are not
details.
They make
the design.

Charles Eames

TRAMMA

LUCA COLOMBO

TRAMA

LC 71 Design:
Luca Colombo



CM/CR
Cromat/Cromo
Matt chrome/Chrome

LC 71 R-RY Ø50



CM/CR

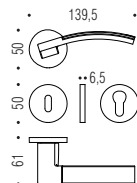

FF 19 BZG Ø50



CM



LC 72 IM



CM/CR

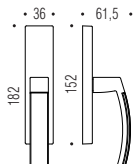

LC 72 DK/SM



CM/CR

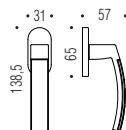



Materiale: Cromall®
Material: Cromall®





TRAMMA

LUCA COLOMBO

TRAMA

LC 81 Design:
Luca Colombo



CM/CR
Cromat/Cromo
Matt chrome/Chrome

LC 81 R-RY Ø50



CM/CR

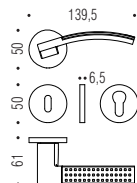

FF 19 BZG Ø50



CM



LC 82 IM



CM/CR

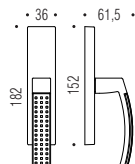

LC 82 DK/SM



CM/CR

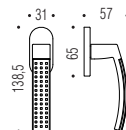



Materiale: Cromall®
Material: Cromall®

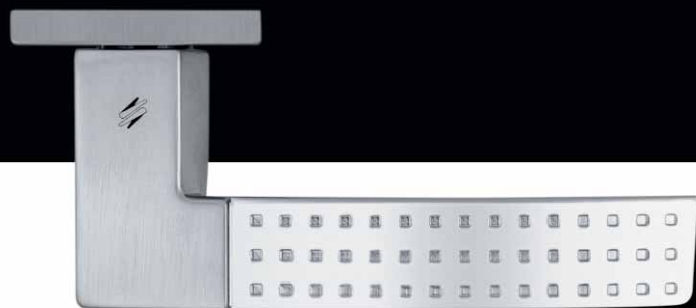



TWITTU

TOMO KIMURA

TWITTY

TK 11 Design:
Tomo Kimura



OL
Oroplus



CM
Cromat
Matt chrome



CR
Cromo
Chrome

TK 11 R-RY Ø50

CD 49 BZG G Ø50



OL - CR - CM

OL - CR - CM

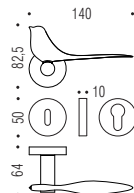



Materiale: Ottone
Material: Brass



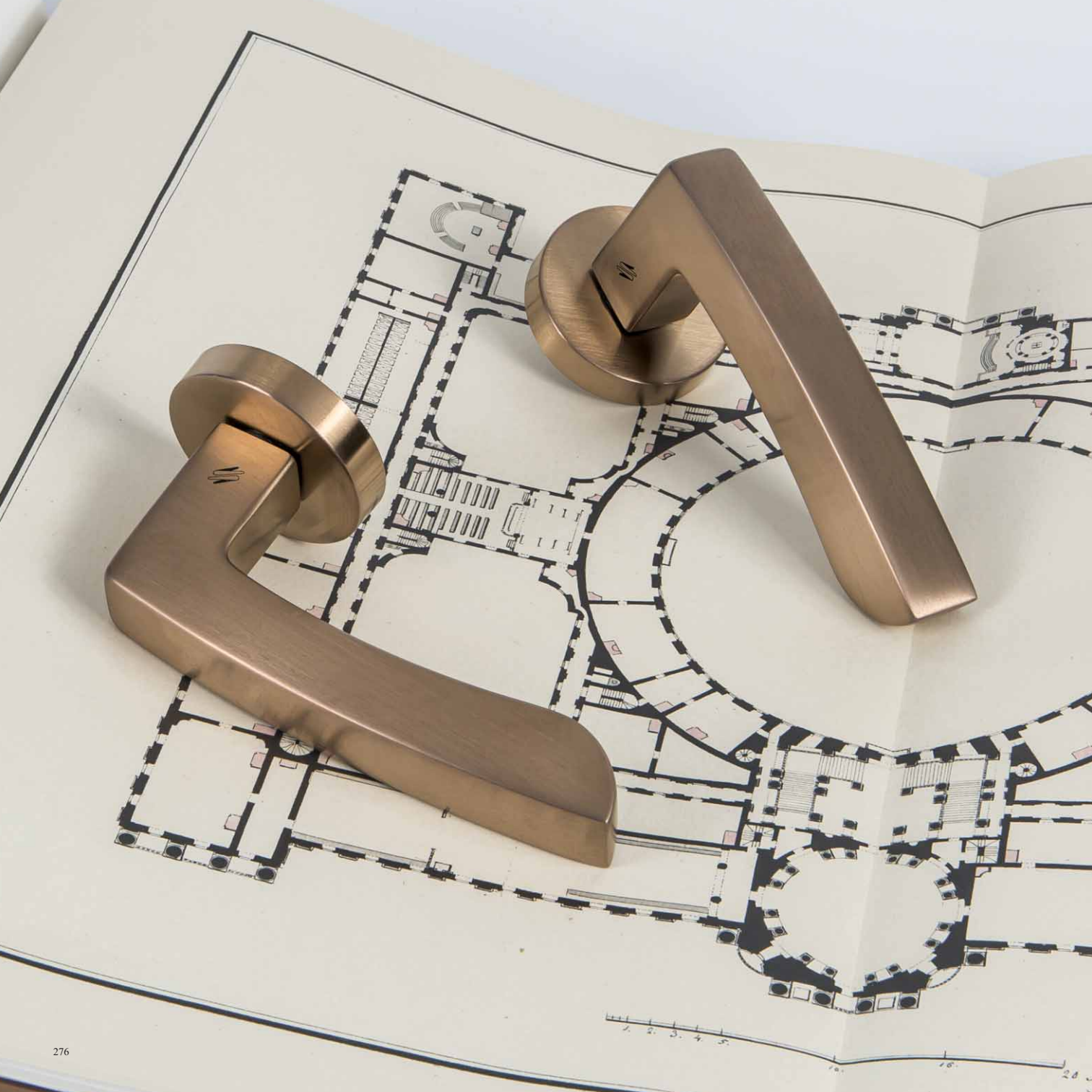

VIOLA

ANGELETTI RUZZA DESIGN

VIOLA

AR 21 Design:
Angeletti Ruzza Design



OL
Oroplus

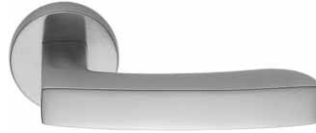

CM
Cromat
Matt chrome

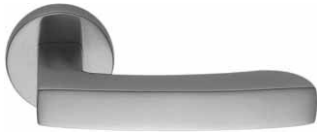

HPS/1
Zirconium
Stainless-steel



VL
Vintage



CR
Cromo
Chrome



VM
Vintage Mat

AR 21 R-RY Ø50

CD 49 BZG G Ø50

AR 22 IM

AR 22 DK/SM



OL-HPS/1-CR-CM-VL-VM

OL-HPS/1-CR-CM-VL-VM

OL-HPS/1-CR-CM-VL-VM

OL-HPS/1-CR-CM-VL-VM

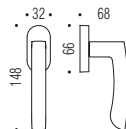
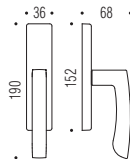
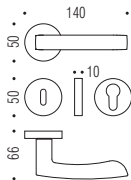



Materiale: Ottone
Material: Brass





WING

DI BLASI ASSOCIATI

WING

DB 31 Design:
Di Blasi Associati



OL
Oroplus



CM
Cromat
Matt chrome

DB 31 R-RY Ø50

CD 49 BZG G Ø50

DB 32 IM

DB 32 DK/SM



OL - CM

OL - CM

OL - CM

OL - CM

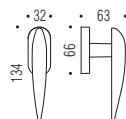
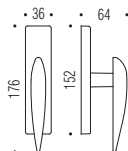
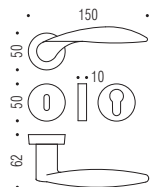



Materiale: Ottone
Material: Brass



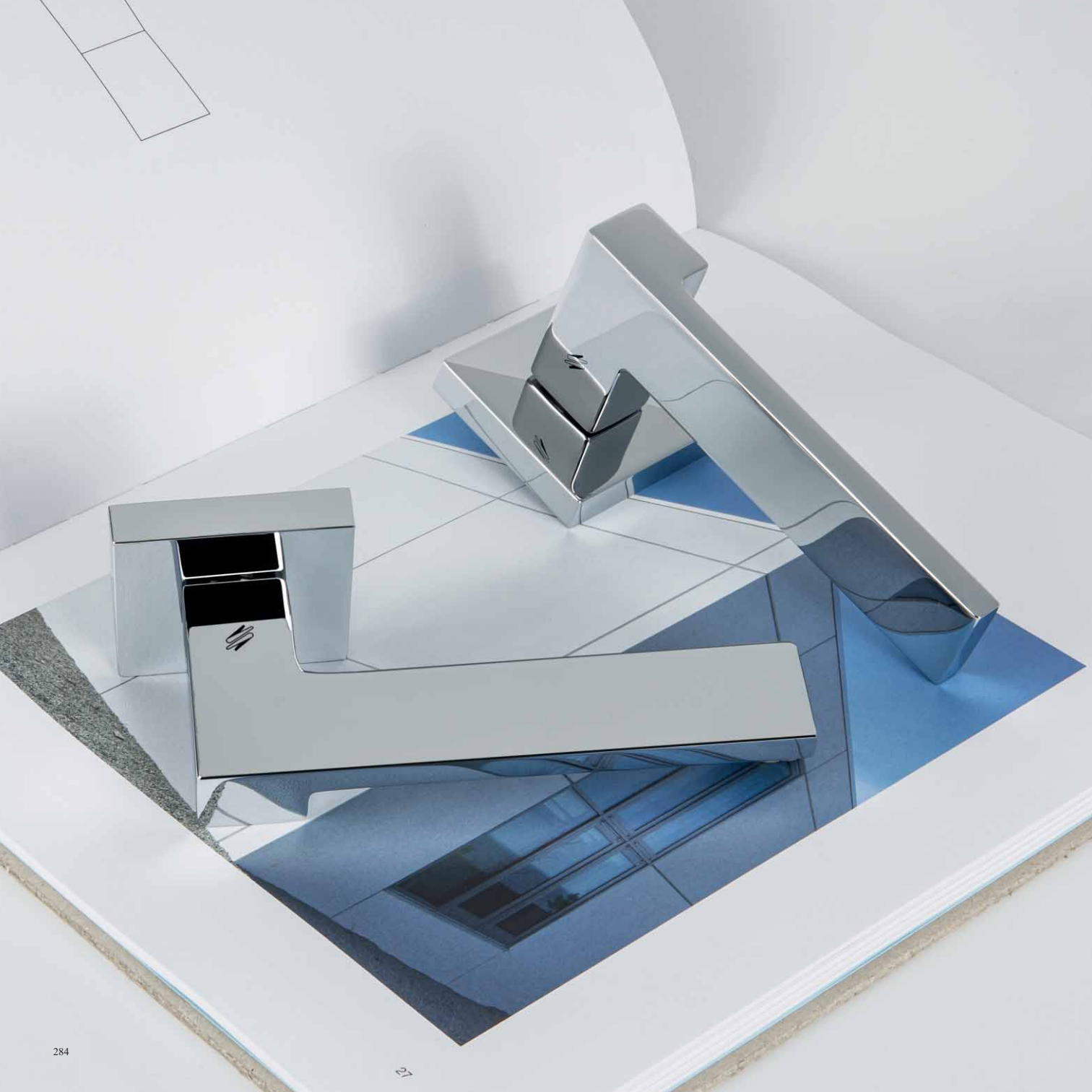

ZELDA

JEAN MARIE MASSAUD

ZELDA

MM 11 Design:
Jean Marie Massaud



CR
Cromo
Chrome



CM
Cromat
Matt chrome

MM 11 R-RY 52x52



CR - CM

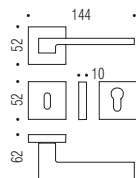

MM 29 BZG 52x52



CR - CM

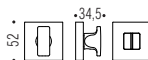

MM 12 IM



CR - CM

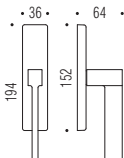

MM 12 DK/SM



CR - CM

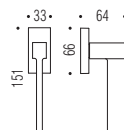



Materiale: Ottone
Material: Brass

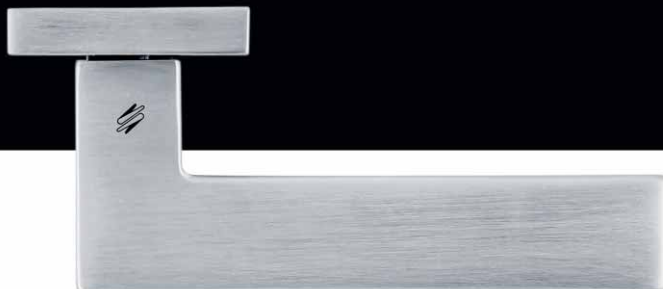

ZELDA

MM 11 Design:
Jean Marie Massaud



CR
Cromo
Chrome



CM
Cromat
Matt chrome

MM 11 RF-RYF 50x50

FF 29 BZG 50x50

MM 12 DKF/SM



CR - CM

CR - CM

CR - CM

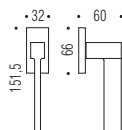
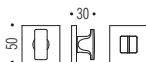
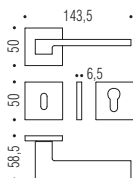



Materiale: Ottone
Material: Brass

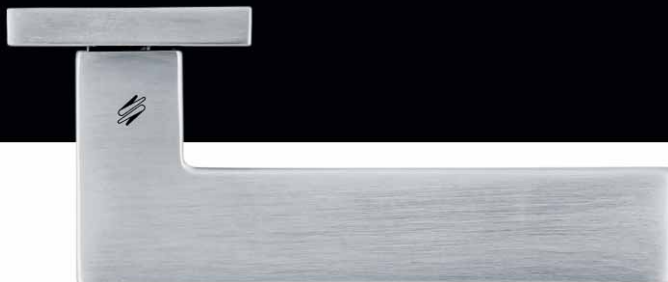

2024 EDITION

Classic Line

MADE IN ITALY

CAMEO

OTTAVIO DI BLASI

CAMEO

DB 41 Design:
Ottavio Di Blasi



OL
Oroplus



BR
Bronzo
Bronze



CR
Cromo
Chrome

DB 41 P-PY

DB 41 R-RY 63x50

DB 19 BZG 63x50

DB 42 IM

DB 42 DK/SM



OL - CR - BR

OL - CR - BR

OL - CR - BR

OL - CR - BR

OL - CR - BR

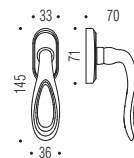
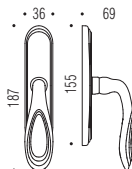
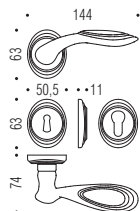
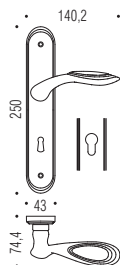



Materiale: Ottone
Material: Brass



La ricerca Susanna e

Osservando le differenti versioni
chioni risulta chiaro che, per que-
si, un progetto ben preciso da real-
no la tendenza di Rembrandt a real-
del quadro. Una tendenza simile era
ne del dipinto *I sindaci dei drappieri*,
rappresentazione di un evento tempora-
da Rembrandt a prtori, ma dovevano
servare. Le differenti versioni a
tappe di questa ricerca.

Il testo biblico apocrifo di uno stesso
stimato signore che, durante il libro di Dani-
sedeva una ricca casa con giardini dove soleva
siti vi erano anche due anziani che rivestivano l'
inamorati della bella moglie di Ioakim, Susanna
carono di nascosto da lei mentre facevano i
giardino sono chiuse, nessuno ci vede e noi brucia-
consenti e concediti a noi. In caso contrario ti accusa-
vate era con te e perciò hai fatto uscire le ancelle". Su-
non potrà scappare dalle vostre mani. Meglio però per
nelle vostre mani che peccare davanti al Signore".
viene ingiustamente accusata e condannata a morte. Su-
zo i due vecchi vengono interrogati separatamente.
loro colpevolezza. Il giovane è Daniele.
La prima versione del tema di Susanna
molti dei quadri a soggetto separatamente.
suo maestro. Di quest'opera
costellazione dell'

HEIDI

COLOMBO DESIGN

HEIDI

CD 31 Design:
Colombo Design



OL
Oroplus



BR
Bronzo
Bronze

CD 31 P-PY



OL - BR

CD 31 R-RY Ø50



OL - BR

CD 69 BZG G Ø50



OL - BR

CD 32 M



OL - BR

CD 32 DK/SM DX-SX



OL - BR

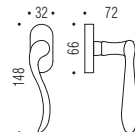
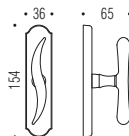
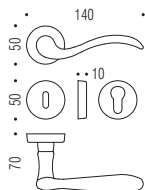
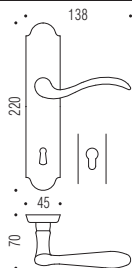



Materiale: Ottone
Material: Brass



IDA

COLOMBO DESIGN



OL
Oroplus



CR
Cromo
Chrome



BR
Bronzo
Bronze



OA
Ottone antico
Antique brass



BA
Bronzo antico
Antique bronze

ID 31 P-PY



OL - BR - OA - BA

ID 31 R-RY Ø50



OL - CR - BR - OA - BA

CD 69 BZG G Ø50



OL - CR - BR - OA - BA

ID 32 M



OL - CR - BR - OA - BA

ID 32 DK/SM



OL - CR - BR - OA - BA

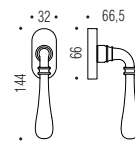
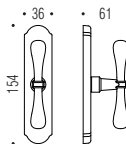
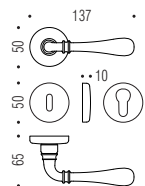
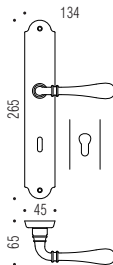



Materiale: Ottone
Material: Brass





133

PETER

COLOMBO DESIGN

PETER

ID 11 Design:
Colombo Design



OL
Oroplus



BR
Bronzo
Bronze



OM
Oromat
Matt gold



OA
Ottone antico
Antique brass

ID 11 P-PY



OL - OM - BR - OA

ID 11 R-RY Ø50



OL - OM - BR - OA

CD 69 BZG G Ø50



OL - OM - BR - OA

CD 32 M



OL - OM - BR - OA

ID 12 DK/SM DX-SX



OL - OM - BR - OA

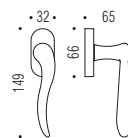
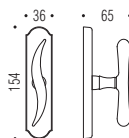
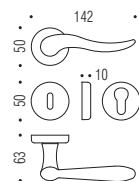
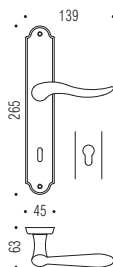



Materiale: Ottone
Material: Brass



PIUMA

ANGELETTI RUZZA DESIGN

PIUMA

AR 11 Design:
Angeletti Ruzza Design



OL
Oroplus



BR
Bronzo
Bronze

AR 11 P-PY



OL - BR

AR 11 R-RY Ø50



OL - BR

CD 79 BZG Ø50



OL - BR

AR 12 M



OL - BR

AR 12 DK/SM



OL - BR

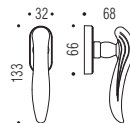
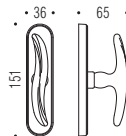
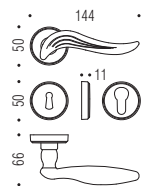
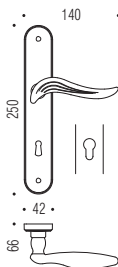



Materiale: Ottone
Material: Brass



La funzione
del design è di
permettere
al design
di funzionare.

The function
of design is
letting design
function.

Micha Commeren

2024 EDITION

ROBOTECH®

MADE IN ITALY



MACH

COLOMBO DESIGN

MACH

CD 81 Design: Colombo Design



HPS
Zirconium Gold



CM
Cromat
Matt chrome



OL
Oroplus



NI
Nikelmat
Matt nickel



OM
Oromat
Matt gold



OA
Ottone antico
Antique brass

CD 81 P-PY

CD 81 R-RY Ø50

CD 69 BZG G Ø50

CD 82 IM

CD 82 DK/SM



HPS - OL - CM - OA

HPS-OL-OM-CM-NI-OA

HPS-OL-OM-CM-NI-OA

HPS-OL-OM-CM-NI-OA

HPS-OL-OM-CM-NI-OA

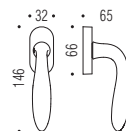
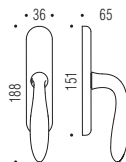
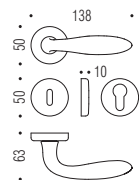
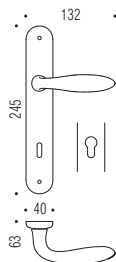



Materiale: Cromall®/Ottone
Material: Cromall®/Brass



www.digitalic.it

Storici

tecnologia / business /

INTELLIGENZA LABORATORIO



11/2018_n. 78

Cartoncino CKB Nude™
by Stora Enso 230 g/m²

Stampa quadricromia

Nobilitazione digital

Foil

ROBOT

COLOMBO DESIGN

ROBOT

CD 41 Design:
Colombo Design



OL
Oroplus



NM RAL 9005
Neromat
Matt Black



CR
Cromo
Chrome



BI RAL 9016
Biancomat
Matt White



CM
Cromat
Matt chrome



CD 41 P-PY

CD 41 R-RY Ø50

CD 69 BZG G Ø50

CD 42 M

CD 42 IM

CD 42 PL

CD 42 DK/SM

CD 42 DK Z



OL - CR - CM

OL - CR - CM - NM - BI

OL - CR - CM - NM - BI

OL - CR - CM - NM - BI

OL - CM

OL - CR - CM

OL - CR - CM - NM - BI

OL - CR - CM

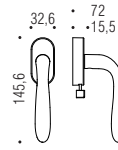
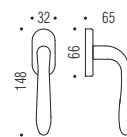
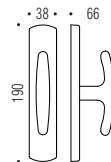
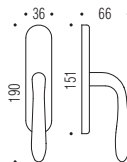
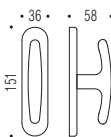
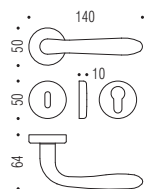
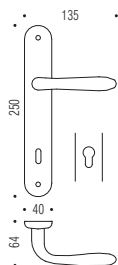



Materiale: Cromall®
Material: Cromall®





ROBOT

COLOMBO DESIGN

ROBOT

CD 75 Design:
Colombo Design



HPS
Zirconium Gold



CM
Cromat
Matt chrome



OM
Oromat
Matt gold



BR
Bronzo
Bronze



CR
Cromo
Chrome

CD 75 R-RY Ø50

CD 69 BZG G Ø50



HPS - OM - CR - CM - BR

HPS - OM - CR - CM - BR

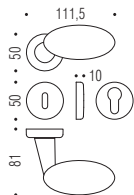



Materiale: Ottone
Material: Brass





SuperNOV 2019

ROBODUE

COLOMBO DESIGN

ROBODUE

CD 51 Design:
Colombo Design



OL
Oroplus



CR
Cromo
Chrome



CM
Cromat
Matt chrome

CD 51 P-PY



OL - CR - CM

CD 51 R-RY Ø50



OL - CR - CM

CD 69 BZG G Ø50



OL - CR - CM

CD 52 M



OL - CR - CM

CD 52 DK/SM



OL - CR - CM

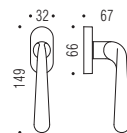
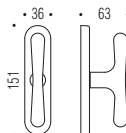
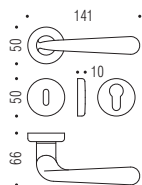
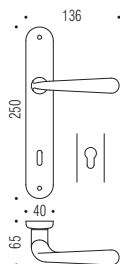



Materiale: Cromall®
Material: Cromall®



UNICATION

...collaboration ... il business

...le tecnologie digitali di collaboration innovative vanno
... sono in grado di definire nuovi modelli di lavoro, con

A cura della redazione

... la Unified Communication
... smart working

Le implementazioni di collaboration sono sempre più orientate verso un modo da favorire un'esecutiva e multicanale.

I trend di mercato

Michele Dalmazzoni, Collaboration & Industry Italia, ci aiuta a fotografare il mercato e a tracciare una panoramica dei trend in atto. Osservando lo scenario è possibile identificare diversi macrotrend che in questo momento riguardano il particolare: i modelli di consumo, con una netta predilezione verso le architetture Cloud e ibride. Le aziende stanno avvalendo soluzioni di collaboration in Cloud per la semplicità di deployment, la facilità di eseguire aggiornamenti, l'agilità del servizio. Sono molto diffusi anche modelli ibridi, in particolare nei casi in cui sono necessarie integrazioni con infrastrutture legacy o vi siano esigenze di business.



ROBOTRE

COLOMBO DESIGN

ROBOTRE

CD 91 Design:
Colombo Design



HPS
Zirconium Gold



CR
Cromo
Chrome



OL
Oroplus



CM
Cromat
Matt chrome



OM
Oromat
Matt gold



BR
Bronzo
Bronze



CD 91 P-PY

CD 91 R-RY Ø50

CD 69 BZG G Ø50

CD 92 IM

CD 92 DK/SM

CD 92 DK Z



OL - CM

HPS-OL-OM-CR-CM-BR

HPS-OL-OM-CR-CM-BR

HPS-OL-OM-CR-CM-BR

HPS-OL-OM-CR-CM-BR

OL - CR - CM

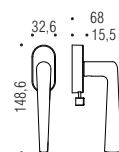
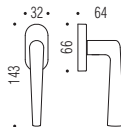
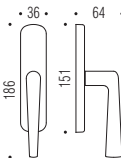
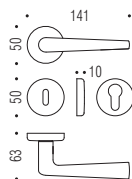
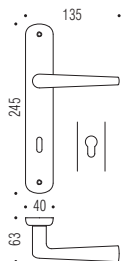



Materiale: Cromall®/Ottone
Material: Cromall®/Brass



RTINET

C,
ELO
UTC
ATA

QUALE STRATEGIA DEVONO METTERE IN ATTO LE IMPRESE PER PROTEGGERSI AL MEGLIO?

L'evoluzione digitale richiede un nuovo approccio alla sicurezza. Serve un cambio di passo, che deve essere sposato sia dal management che dai dipendenti. Per riuscire a contrastare gli sforzi continui dei criminali informatici, le organizzazioni devono includere le strategie di sicurezza nei loro sforzi di digital transformation. Devono inserirli nei piani di sviluppo e di crescita e comprendere che non si tratta di un costo, ma di un investimento.

che nel cloud. Questo approccio di condividere una threat intelligence utilizzabile in modo rapido e riduce le finestre di rilevamento e fornisce una risoluzione necessaria per gli exploit di oggi. Consente quindi di offrire più soluzioni per reagire all'unisono alla minaccia. Velocità, integrazione e automazione sono fondamentali per la difesa. Fortinet integra per questo Fortinet Security Fabric rivolge alle imprese dimensioni, dalle piccole infatti devono avere una difesa, le differenze di investimento

correlata e condivisa tra tutti gli elementi di sicurezza deve essere automatizzata per ridurre le finestre di rilevamento e fornire una soluzione rapida. L'integrazione dei singoli prodotti attraverso la rete distribuita, combinata alla segmentazione strategica, contribuirà in modo significativo a combattere la natura sempre più intelligente e automatizzata degli attacchi. I dispositivi di sicurezza di legacy e isolati e una scarsa considerazione della sicurezza continuano a rappresentare un pericolo e aumentano il rischio nel panorama delle minacce odierne, poiché non forniscono visibilità o controllo adeguati. Invece, "security fabric", un tessuto di sicurezza che copra tutto l'ambiente di rete esteso e integrato tra ogni elemento, è vitale per comprendere il panorama odierno e rispondere in continua crescita e per ridurre la superficie di attacco in

IN QUESTO
SEMPRE
(SOFTWARE)
NETWORKS
RETI
INTELLIGENTE
IN S
La
S

COS'È IL SECURITY FABRIC?

È l'approccio di Fortinet al tema della cyber security, è l'insieme di soluzioni per rispondere alle minacce complesse. Una piattaforma organicamente integrata da zero, che offre un ampio set di funzionalità di sicurezza con automazione eccezionali, semplificando l'implementazione in modo

avversari continuano a incorporare nuove minacce e a sfruttare tecniche sempre più automatizzate in termini di velocità e scalabilità per le loro attività dannose, segmentazione e integrazione diventano elementi critici di sicurezza strategica per gli ambienti IT e OT odierni. Non esiste una strategia di difesa futura che includa l'automazione o il machine learning senza un mezzo per raccogliere, elaborare e agire sulle informazioni sulle minacce in modo integrato per produrre una difesa intelligente.

Fortinet continuano a colpire le minacce. Lo confermano le analisi del team FortiGuard Labs del Global Threat Landscape

informatici crescono in modo esponenziale e ogni organizzazione deve tenere conto dell'impatto, con rilevazioni di minacce in crescita. Prima, il volume di dati è in crescita, ora è la qualità. Ogni giorno, ora



ROBOQUATTRO

COLOMBO DESIGN

ROBOQUATTRO

ID 41 Design:
Colombo Design



OL
Oroplus



CM
Cromat
Matt chrome



OM
Oromat
Matt gold



BI RAL 9016
Biancomat
Matt White



CR
Cromo
Chrome



NM RAL 9005
Neromat
Matt Black



ID 41 R-RY Ø50

CD 49 BZG G Ø50

ID 42 IM

ID 42 DK/SM

ID 42 DK Z



OL - OM - CR - CM - BI - NM

OL - OM - CR - CM - BI - NM

OL - OM - CR - CM - BI - NM

OL - OM - CR - CM - BI - NM

OL - CR - CM

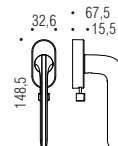
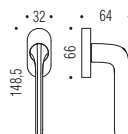
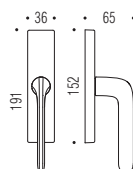
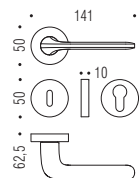



Materiale: Cromall®
Material: Cromall®



The image shows two modern, brushed-bronze door handles. One handle is positioned diagonally across the upper left, and the other is positioned horizontally across the lower right. They are set against a background of a grid of squares, each containing a three-dimensional, isometric cube-like structure. The artwork is a combination of charcoal, grease pencil, and oil on cardboard. The handles have a small, stylized logo on their curved sections. The overall composition is clean and architectural.

olio su cartone / Charcoal, grease pencil, oil on cardboard, 181 x 121 cm.

ROBOQUATTROS

COLOMBO DESIGN

ROBOQUATTROS

ID 51 Design: Colombo Design



OL
Oroplus



VL
Vintage



CR
Cromo
Chrome



VM
Vintage Mat



CM
Cromat
Matt chrome



NM RAL 9005
Neromat
Matt Black



ID 51 R-RY 52x52

PT 19 BZG 52x52

ID 42 IM

ID 52 DK/SM

ID 52 DK Z



OL - CR - CM - VL - VM - NM

OL - CR - CM - VL - VM - NM

OL - CR - CM - VL - VM - NM

OL - CR - CM - VL - VM - NM

CR - CM

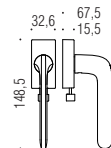
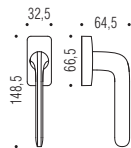
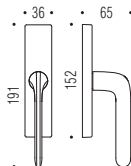
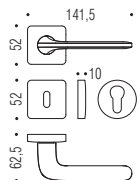



Materiale: Cromall®
Material: Cromall®





ROBOCINQUE

COLOMBO DESIGN

ROBOCINQUE

ID 61 Design:
Colombo Design



OL
Oroplus



NM RAL 9005
Neromat
Matt Black



CR
Cromo
Chrome



BI RAL 9016
Biancomat
Matt White



CM
Cromat
Matt chrome



ID 61 R-RY Ø50

CD 49 BZG G Ø50

ID 62 IM

ID 62 DK/SM

ID 62 DK Z

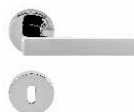

OL - CR - CM - NM - BI

OL - CR - CM - NM - BI

OL - CR - CM - NM - BI

OL - CR - CM - NM - BI

OL - CR - CM

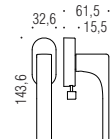
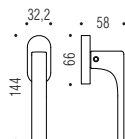
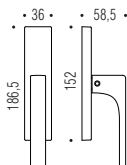
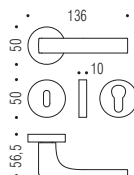

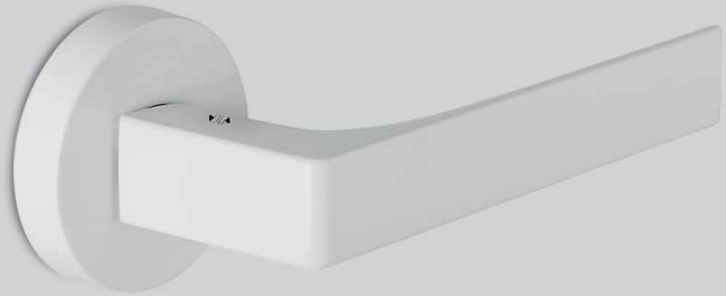

Materiale: Cromall®
Material: Cromall®



ROBOCINQUES

COLOMBO DESIGN

ROBOCINQUE S

ID 71 Design:
Colombo Design



CR
Cromo
Chrome



GL
Grafite
Graphite



CM
Cromat
Matt chrome



GM
Grafite Mat
Matt graphite



BI RAL 9016
Biancomat
Matt White



NM RAL 9005
Neromat
Matt Black



ID 71 R-RY 52x52

MM 29 BZG 52x52

ID 62 IM

ID 72 DK/SM

ID 72 DK Z



CR - CM - GL - GM - NM - BI

CR - CM - GL - GM - NM - BI

CR - CM - GM - NM - BI

CR - CM - GL - GM - NM - BI

CR - CM

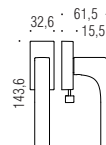
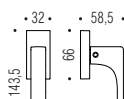
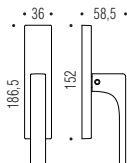
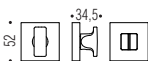
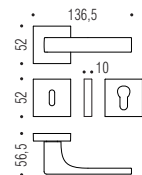



Materiale: Cromall®
Material: Cromall®



Il buon design
è ovvio.
Il grande
design è
trasparente.

Good design
is obvious.
Great design
is transparent.

Joe Sparano

